



cook's essentials®

4QT. DIGITAL AIR FRYER

INSTRUCTION MANUAL

Before operating your new appliance, please read all instructions carefully and keep for future reference.



Questions? Elite's customer service team is ready to help.
Call us toll-free at 800-365-6133 ext. 120/107/105.
For more Elite products, visit us at www.maxi-matic.com.

TABLE OF CONTENTS

IMPORTANT SAFEGUARDS	2
SHORT CORD PURPOSE AND POLARIZED PLUG WARNING	3
PARTS IDENTIFICATION	4
HOW TO USE THE CONTROL PANEL	5
PREPARING YOUR AIR FRYER FOR USE	6
HOW TO USE YOUR AIR FRYER	6
CLEANING & MAINTENANCE	9
CLEANING TIPS	10
COOKING TIME CHART	11
HINTS & TIPS	12
TROUBLESHOOTING	13
WARRANTY & CUSTOMER SERVICE	15

IMPORTANT SAFEGUARDS

When using electrical appliances, basic safety precautions should always be followed, including the following:

1. Read all instructions before using your Cook's Essentials *Air Fryer*.

Danger

2. Never immerse the power cord, plug or housing in water or under the tap.
3. Make sure no liquid enters the appliance to prevent electric shock or short-circuit.
4. Do not cover the air inlet and outlet of the appliance during operation.
5. Always place foods to be cooked in the Drawer Pan, foods should never come into direct contact with the heating elements.
6. Never fill the pan with oil as this may cause a fire hazard and damage to the appliance.
7. Never touch the inside of the appliance during operation (pan, fry rack, etc.)

Warning

8. Make sure that your output voltage corresponds to the voltage stated on the rating label of the appliance.
9. If the supply cord is damaged, it must be replaced by a special cord or assembly available from the manufacture or its service agent.
10. It is recommended to regularly inspect the appliance to avoid a hazard. Do not operate any appliance with a damaged cord or plug or after the appliance malfunctions or has been damaged in any manner. Return appliance to the nearest authorized service facility for examination, repair, or adjustment.
11. Never attempt to repair the appliance yourself, otherwise the warranty becomes invalid.
12. This appliance is not intended for use by persons (including children) with reduced physical, sensory or mental capabilities, or lack of experience and knowledge, unless they have been given supervision or instruction concerning use of the appliance by a person responsible for their safety.
13. Close supervision is necessary when appliance is used near children.
14. NEVER ALLOW A CHILD TO USE THIS PRODUCT.
15. DO NOT let the power cord hang over the edge of the table or work-top, and keep it away from any hot surfaces.
16. Do not plug in the appliance or operate the control panel with wet hands.
17. Do not place or use the appliance on or near combustible materials, such as a table-cloth, curtains or wallpaper.
18. Only connect the appliance to a grounded wall socket. Always make sure that the plug is inserted into the wall socket properly.
19. Never connect this appliance to an external timer switch in order to avoid a hazardous situation.
20. Never leave appliance unattended.
21. Appliance surfaces may become hot during use.
22. The appliance should be placed on a horizontal and stable surface when using. Do not place on plastics, board or any other easy-wear surface.
23. Do not place the appliance against wall or other appliances, leave around 4 inches of space from nearby objects. Do not place anything on the top of appliance.
24. Do not use the appliance beyond the specification of this manual.
25. During operation, hot steam will exhaust through the hind side air outlet. Keep your hands and face at a safe distance from the steam and the air outlet openings. Also be careful of hot steam and air when you remove the pan from the appliance.
26. If food burns and dark smoke releases from the air outlet, unplug immediately and wait for smoke release to stop, then clean the food and oil from the pan and fry rack.

IMPORTANT SAFEGUARDS

Caution

27. After use, turn off power to the appliance then unplug from the wall outlet.
28. Unplug the appliance from outlet when it is not in use or before cleaning. Allow it to cool down first before cleaning.
29. Do not use any accessories that have not been provided with the appliance.
30. This appliance is intended to be used indoors. Do not use outdoors.
31. Clean and wipe and dry the pan and the fry rack before placing food inside.
32. Do not power on the Air Fryer when the Top Lid is open.
33. Always unplug the appliance when not in use.
34. If the appliance is of the grounded type, the extension cord should be a grounded cord.
35. To ensure continued protection against risk of electric shock, connect to properly grounded outlets only.
36. Some countertop and table surfaces, such as Corian®, wood and / or laminates, are not designed to withstand prolonged heat generated by certain appliances. It is recommended by countertop manufacturers and Maxi-Matic that a hot pad or trivet be placed under your appliance to prevent possible damage to the surface.

SAVE THESE INSTRUCTIONS HOUSEHOLD USE ONLY

SHORT CORD PURPOSE

NOTE: A short power cord is provided to reduce the risk of personal injury resulting from becoming entangled in or tripping over a longer cord.

Longer power-supply cords or extension cords are available and may be used if care is exercised in their use.

If an extension cord is used: (1) the marked electrical rating of the extension cord should be at least as great as the electrical rating of the product; (2) the extension cord should be arranged so that it will not drape over the countertop or tabletop where it can unintentionally be pulled on or tripped over by children or pets.

POLARIZED PLUG

If this appliance is equipped with a **polarized plug** (one blade is wider than the other), please follow the below instructions:

To reduce the risk of electrical shock, this plug is intended to fit into a polarized outlet only one way. If you are unable to fit the plug into the electrical outlet, try reversing the plug. If the plug still does not fit, contact a qualified electrician. Never use the plug with an extension cord unless the plug can be fully inserted into the extension cord. Do not alter the plug of the product or any extension cord being used with this product. Do not attempt to defeat the safety purpose of the polarized plug.

PARTS IDENTIFICATION

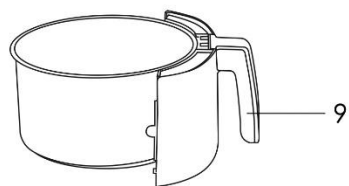
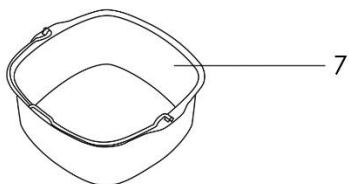
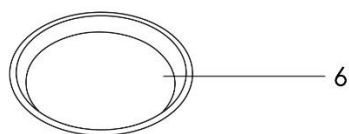
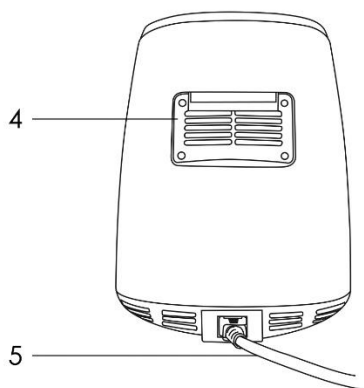
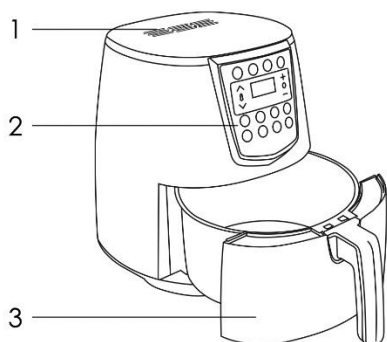

1. Air Inlet
2. Control Panel
3. Pull-Out Drawer Pan
4. Air Outlet
5. Power Cord
6. Pizza Pan
7. Cake Pan
8. Frying Rack
9. Drawer Handle

NOTE

The Pull-Out Drawer Pan (3), Pizza Pan (6), Cake Pan (7), and Frying Rack (8) consist of a non-stick surface. To avoid scratching the non-stick surface, please use heat-proof silicone utensils.

HOW TO USE THE CONTROL PANEL

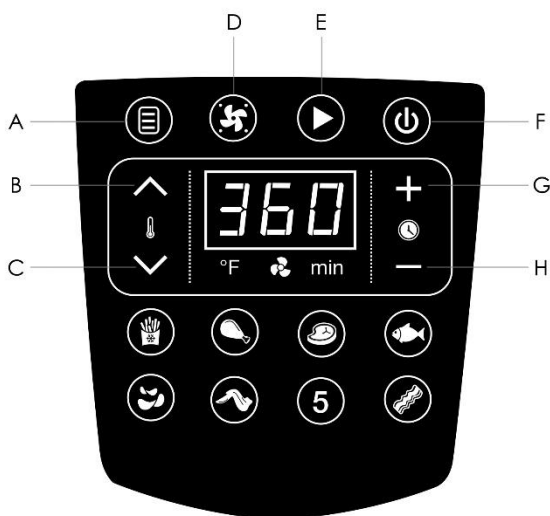

A) MENU BUTTON:

Use this button to toggle through the different menu functions.

B) TEMPERATURE INCREASE BUTTON:

Press to increase the temperature setting by 5-degree increments up to a maximum of 400°F (hold button for rapid increase).

C) TEMPERATURE DECREASE BUTTON:

Press to decrease the temperature setting by 5-degree increments to a minimum of 140°F (hold button for rapid decrease).

D) RAPID COOL BUTTON:

Press to speed up the cooling process of hot food for immediate consumption after cooking.

E) START/STOP BUTTON:

Tap this button to START or STOP cooking. The time and temperature are displayed alternately every 5 seconds.

F) POWER BUTTON:

Tap this button to turn the air fryer ON/OFF.

G) TIMER INCREASE BUTTON:

Each press increases cooking time by one minute up to a maximum of 60-minutes (hold button for rapid increase).

H) TIMER DECREASE BUTTON:

Each press decreases cooking time by one minute (hold button for rapid decrease).

PREPARING YOUR AIR FRYER FOR USE

1. Before using your *Digital Air Fryer* for the first time, carefully remove all packaging materials and recycle appropriately.
2. Remove the parts from the box and wash the Drawer Pan (3), Pizza Pan (6), Cake Pan (7), and Frying Rack (8) with warm, soapy water and a non-abrasive sponge.

IMPORTANT: DO NOT IMMERSE THE MAIN HOUSING IN WATER. Wipe the interior and exterior of appliance clean with a damp cloth.

IMPORTANT: THIS IS NOT A DEEP FRYER. DO NOT FILL THE APPLIANCE OR ITS DRAWER (3) WITH OIL OR FRYING FAT.

3. Place the appliance on a flat, horizontal and stable surface (make sure surface is heat-resistant). Place away from walls and other appliances. Leave approximately 4 inches of space from nearby objects (see Figure 1).

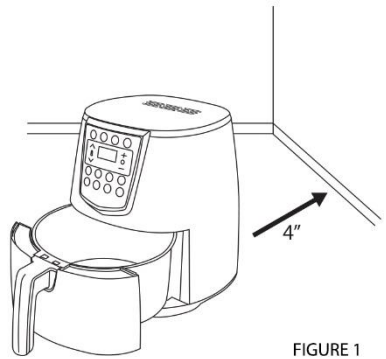

FIGURE 1

HOW TO USE YOUR AIR FRYER

1. Carefully pull out the Drawer Pan (3) from the Main Fryer Body by pulling forward on the Handle (9). (see Figure 2)

TIP: Never place food directly into the Drawer Pan (3) without the Frying Rack (8) inside.

CAUTION: Never place anything on top of the Main Body, for this will block the air flow and reduce the effect of hot air heating.

2. Place the Frying Rack (8) into the Drawer Pan (3) (see Figure 3).
3. Place ingredients onto Frying Rack (8).

TIP: Do not fill the Drawer Pan (3) over the rim with food. If cooking food that expands, make sure the cooked capacity will not exceed the rim of the Drawer Pan (3)

4. Slide Drawer Pan (3) back into the Main Body. (see Figure 4)

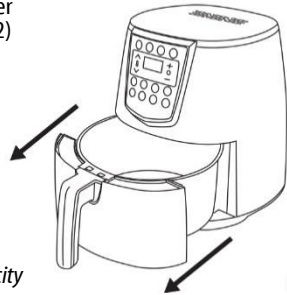

FIGURE 2

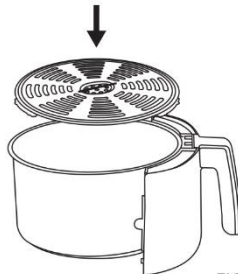

FIGURE 3

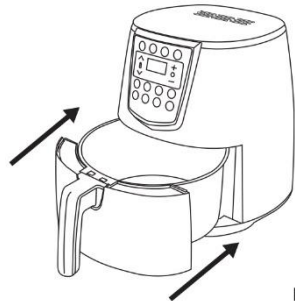

FIGURE 4









HOW TO USE YOUR AIR FRYER (CONT.)

HOW TO MANUALLY PROGRAM FRYING TIME AND TEMPERATURE:

1. Plug Power Cord (5) into an electrical outlet. You will hear a beep and the POWER and COOL DOWN buttons will illuminate.
2. Gently tap the **POWER** button, you will hear a beep and the LED screen will illuminate. The Digital Display will default to 360°F and 15-minutes.
TIP: It is recommended to preheat the air fryer on empty at 360°F for 3-min if the appliance is cold. The initial 15 minutes of use may result in minimal smell and smoke. This is normal and harmless and comes from the protective substance applied to the heating elements during manufacturing.
NOTE: If no function is selected, the air fryer will beep once every 30 seconds during standby.
3. Press the +/- button for the Temperature setting to adjust to the desired temperature. Temperature will increase or decrease in 5-degree increments.
4. Press the +/- button for the Timer setting to adjust to the desired cooking time. Timer will increase or decrease in 1-minute increments.
5. Tap the **START/STOP** Button once to begin cooking.

HOW TO SELECT A QUICK MENU FUNCTION:

QUICK MENU CHART

	MENU	DEFAULT TEMPERATURE	DEFAULT COOK TIME
----	DEFAULT	360°F	15 min
	Frozen French Fries	400°F	18 min
	Chicken	360°F	20 min
	Steak	400°F	12 min
	Fish	400°F	10 min
	Potato Chips	300°F	15 min
	Chicken Wings	400°F	12 min
	Quick 5	400°F	5 min
	BACON	380°F	6 min

HOW TO USE YOUR AIR FRYER (CONT.)

1. Plug Power Cord (5) into an electrical outlet. You will hear a beep and the POWER and COOL DOWN buttons will illuminate.
2. Gently tap the **POWER** button, you will hear a beep and the LED screen will illuminate. The Digital Display will default to 360°F and 15-minute setting.
***TIP:** It is recommended to preheat the air fryer on empty at 360°F for 3 min. if the appliance is cold. The initial 15 minutes of use may result in minimal smell and smoke. This is normal and harmless and comes from the protective substance applied to the heating elements during manufacturing.*
3. Press the **MENU** button to cycle through the different MENU functions. The highlighted MENU function will illuminate and the default MENU Temperatures and Times will appear.
4. To select desired Menu function, tap the **START/STOP** Button once to begin cooking.
5. Use the +/- buttons to adjust MENU function temperatures or times if you wish to change the programmed settings.
***NOTE:** There is no need to press START/STOP button again when changing a setting during the cooking process.*
***Note:** The initial 15 minutes of use may result in minimal smell and smoke. This is normal and harmless and comes from the protective substance applied to the heating elements during manufacturing.*

CANCELING A SELECTION:

1. To cancel any programmed selection, simply tap the **START/STOP** button during the cooking process to cancel the selection.

HOW TO USE THE PIZZA PAN (6) AND CAKE PAN (7):

1. Place Pizza Pan (6) or Cake Pan (7) into the Drawer Pan (3) on top of the Frying Rack (8). Then follow the recipe guidelines to program the cooking Time and Temperature.

DURING THE COOKING/FRYING PROCESS:

1. Once you tap the **START/STOP** Button, the Timer will begin counting down and begin the cooking process.
***NOTE:** Any excess oil from food will collect at the bottom of the Pan (3).*
2. Some recipes require stirring/mixing/flipping the contents mid-way through cooking (see Cooking Time Chart on page 11). You can do this in the middle of the cooking process by simply pulling out the Drawer Pan (3) by grasping the Handle (9) and pulling forward the entire Drawer Pan (3). The built-in auto sensors will automatically pause the heating system to allow you to attend to the food. Or you can press the **START/STOP** button to pause the cooking process.
3. Shake, stir or flip the contents of the Drawer Pan (3) using a non-metallic utensil and then slide Drawer Pan (3) back into the Main Fryer Base.
***CAUTION:** During cooking, the Drawer Pan (3) and Frying Rack (8) will be very hot, only use the cool-touch handles or oven mitts.*

WHEN COOKING/FRYING IS COMPLETE:

1. When the timer completes its countdown, the air fryer will beep five times and stop heating - this signals it is time to remove your food.
***NOTE:** You can also switch off the appliance manually by pressing POWER at any time during the cooking process.*
2. If desired, press the **RAPID COOL BUTTON** to turn on the interior fan for 5-minutes to rapidly cool drawer contents and serve food immediately. To use this function simply press the FAN icon and the fan function will turn on. After 5-min, the unit will beep and the fan will shut off.

HOW TO USE YOUR AIR FRYER (CONT.)

- Carefully pull the Drawer Pan (3) out from the Main Fryer Base by pulling forward on the Drawer Handle (9) and place on a flat, heat resistant surface.
CAUTION: When sliding out the Drawer Pan (3), be careful of hot air and steam. Keep hands and face away from the opening.
CAUTION: After cooking, the Drawer Pan (3) and Frying Rack (8) will be extremely hot to the touch. Do not touch surfaces of the Drawer Pan (3) or Frying Rack (8) directly.
- Check that your foods are ready. If not, then slide the Drawer Pan (3) back into the Main Fryer Base and set the timer for a few more minutes.
- Empty the contents of the Drawer Pan (3) into a bowl or onto a plate using non-metallic tongs or a scoop.
TIP: Do not turn the Drawer Pan (3) and Frying Rack (8) upside down together, as any excess oil that has collected in the bottom of the Drawer Pan (3) will be poured onto the foods.
TIP: If food contents within Drawer Pan (3) are too heavy to lift using the Drawer Handle (9), use oven mitts to carefully pull out the whole Drawer Pan (3) and Frying Rack (8) together. Place on a flat, heat-resistant surface and use Tongs to remove contents from the Frying Rack (8).
- When the next batch of ingredients is ready, the air fryer is instantly ready to use again.
- Remove the Power cord (5) from the electrical outlet.

CLEANING & MAINTENANCE

The **Digital Air Fryer** should be cleaned thoroughly after every use.

- Make sure the Power cord (5) is disconnected from the electrical outlet and that the appliance has cooled down before attempting to clean.
TIP: Use the **RAPID COOL FUNCTION** to quickly cool down parts for cleaning.
- The Drawer Pan (3), Pizza Pan (6), Cake Pan (7), Frying Rack (8) and the inside of the appliance have a nonstick coating. Do not use metal utensils or abrasive cleaning materials on them, as this can damage the nonstick coating.
- Wipe the outside of the appliance with a damp cloth.
- Lift the Pizza Pan (6), Cake Pan (7), or Frying Rack (8) upwards out of the Drawer Pan (3) (Figure 5) and clean both with hot water, dishwashing soap and a non-abrasive sponge.
- You can use a degreaser to remove any stuck-on residue.
NOTE: The Drawer Pan (3), Pizza Pan (6), Cake Pan (7), and Frying Rack (8) are dishwasher-safe (top rack only).
TIP: If food residue is stuck to the Frying Rack (8) or the bottom of the Drawer Pan (3), place the Frying Rack (8) into the Drawer Pan (3) and fill with dishwashing soap and water and let soak for 10 minutes.
- Clean the inside of the appliance with hot water and a non-abrasive sponge.
- Never immerse the power cord, plug or the appliance body in water or any other liquids.
- Dry all parts after each use, re-assemble and store in a cool, dry location.

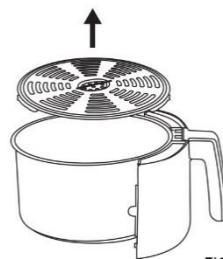

FIGURE 5

CLEANING TIPS



- 1) Soak the Frying Rack in hot water for 15-minutes.



- 2) Discard the water, and allow the Frying Rack to cool before removing carefully.



- 3) Use warm, soapy water and a soft dish cloth to carefully wash the Frying Rack.



- 4) Rinse the Frying Rack.



- 5) Dry the Frying Rack thoroughly with a soft dish cloth.



- 6) Place the Frying Rack back into the Drawer Pan.

COOKING TIME CHART

The chart on this page helps you to program basic times and temperatures for common foods. Please note that all of the information below is for your reference only and can be adjusted according to the user's preference. They are approximations only as foods differ in size and density so cooking times and temperatures cannot be guaranteed.

	Min-max Amount (ounces)	Time (min.)	Temp (°F)	Stir	Notes
Potatoes & fries					
Thin frozen fries	15 ~ 25	11-16	390	Stir	
Thick frozen fries	15 ~ 25	13-20	400	Stir	
Home-made fries (0.3" x 0.3")	15 ~ 30	15-20	400	Stir	add 1/2 tbsp of oil
Home-made potato wedges	15 ~ 30	20-22	355	Stir	add 1/2 tbsp of oil
Home-made potato cubes	15 ~ 25	14-18	355	Stir	add 1/2 tbsp of oil
Home-made potato chips	10	9-10	320		
Meat & Poultry					
Steak	6 ~ 18	9-12	355		
Pork chops	6 ~ 18	11-14	355		
Hamburger	6 ~ 18	8-14	355		
Drumsticks	6 ~ 18	19-22	350		
Chicken Wings	15 ~ 20	16-18	400		
Chicken Strips	6 ~ 18	12-15	355		
Snacks					
Egg rolls	6 ~ 18	9-10	395	Stir	Use oven-ready
Frozen chicken nuggets	6 ~ 18	7-10	400	Stir	Use oven-ready
Frozen fish sticks	6 ~ 14	7-10	400		Use oven-ready
Fish fillet in batter	6 ~ 18	8-14	355	Stir	
Battered shrimp	6 ~ 18	8-13	355	Stir	
Frozen bread crumbed cheese sticks	6 ~ 14	9-10	360		Use oven-ready
Stuffed vegetables	6 ~ 14	10	320		
Mushrooms	6 ~ 14	10	320		
Onion Rings	6 ~ 18	8-13	355		
Baking					
Cake	10	20-25	320		Use Cake Pan (7)
Quiche	15	20-22	355		Use Pizza Pan (6) or Cake Pan (7)
Muffins	10	15-18	390		Use oven-safe muffin cups (not included)
Sweet snacks	15	20	320		Use Pizza Pan (6) or Cake Pan (7)

HINTS & TIPS

TIPS

- Smaller cuts of foods usually require a slightly shorter cooking time than larger foods.
 - A larger amount of foods only requires a slightly longer cooking time and a smaller amount of foods only requires a slightly shorter cooking time.
 - Stirring or shaking smaller foods mid-way through the cooking process will improve the end result and can help cook more evenly.
 - Adding a small amount of oil to fresh potatoes can result in a crispier result. Cook your ingredients in the air fryer within a few minutes after adding the oil.
 - Do not air fry extremely greasy foods such as sausages in the air fryer.
 - Snacks that can be prepared in an oven can also be prepared in the air fryer.
 - The optimum amount for air frying crispy fries is 17.5 ounces or a little over 1 lb.
 - Use pre-made dough to prepare foods with fillings quickly and easily. Pre-made dough also requires a shorter cooking time than home-made dough.
 - The air fryer can also reheat foods. To reheat foods, set the temperature to 300°F for up to 10 minutes.
 - To cook frozen foods, add an additional 3-5 minutes to your cook time.
- Note:** When cooking/baking foods that rise (i.e. cakes, quiches or muffins) the Cake Pan (7) should not be filled more than halfway.
- Note:** Add 3 minutes to the cooking time if you begin cooking while the air fryer is still cold.

BAKING CAKES/QUICHES

- Place an oven-safe dish, Pizza Pan (6), or Cake Pan (7) into the Drawer Pan (3) on top of the Fry Racking (8) if you want to bake a cake/quiche, steam foods or if you want to air fry delicate foods or foods with fillings.

HOME-MADE FRENCH FRIES

When making your own French fries, follow these steps:

1. Peel potatoes and slice them into strips.
2. Wash and dry them thoroughly.
3. Mix potato strips in a bowl with ½ tablespoon of olive oil, make sure they are evenly coated.
4. Using your hands or tongs, place the potato strips into the Drawer Pan (3).
5. **NOTE:** Do not pour the potato sticks from the bowl into the Drawer Pan (3) because we don't want to transfer any excess oil into the Drawer Pan (3).

TROUBLESHOOTING GUIDE

Problem	Possible cause	Solution
The air fryer does not work.	The appliance is not plugged in.	Plug the power cord (5) into an electrical outlet.
		You did not press the POWER button.
	The appliance is defective.	Contact customer service at www.maxi-matic.com
Food not completely cooked/fried.	There is too much food in the Drawer Pan (3).	Use smaller batches of food in the Drawer Pan (3). Small batches of food will cook more evenly.
	The cooking temperature is set too low.	Increase the temperature setting. Check "Cooking Time Chart" found in this manual.
	The cooking time is too short.	Increase the time setting. Check "Cooking Time Chart" found in this manual.
Food cooked is uneven.	Certain foods need to be stirred/mixed mid-way through the cooking process.	Foods that overlap inside the Drawer Pan (3) need to be stirred mid-way through cooking. Go to section: 'During the Cooking/Frying Process' in this manual.
Fried snacks are not crispy.	You used a type of snack meant to be prepared in a traditional deep fryer.	Use oven snacks or lightly brush some oil onto the snacks for a crispier result.
I cannot close the Drawer Pan (3) properly.	The Drawer Pan (3) is too full.	Do not fill the Drawer Pan (3) above the rim.
	The Drawer Pan (3) is not properly placed into air fryer.	Make sure there is no obstruction for the Drawer Pan (3) to close properly.
White smoke is emitted out of the appliance during use.	You are preparing food with a high oil content.	When cooking with oily foods, oil will drain into the Drawer Pan (3). When the air fryer heats up, the pan heats up the oil and produces white smoke. This does not adversely affect the air fryer or your cooking process.
	The pan has built-up oil residue from previous uses.	White smoke is caused by oil leftover in the Drawer Pan (3). Make sure to thoroughly clean the Drawer Pan (3) after every use.
Home-made French fries are coming out unevenly cooked.	Your potatoes are not fresh or are frozen.	Make sure to use fresh and firm potatoes. Not frozen potatoes for home-made French fries.
	Potato strips were not thoroughly rinsed prior to frying.	Thoroughly rinse sliced potato to remove all starch prior to frying.
Your home-made French fries are not crispy after air frying.	Crispy results are directly linked to the amount of oil and water content of the fresh potato strips.	Potato strips need to be thoroughly dried before adding oil.

		Slice potato strips thinner if you want them crispier.
		Use a bit more oil on the potato strips prior to frying if you want crispier results.

LIMITED WARRANTY* ONE (1) YEAR
WARRANTY IS ONLY VALID WITH A DATED PROOF OF PURCHASE

PLEASE DO NOT RETURN TO STORE OF PURCHASE.

If you have any problems with this unit, contact Customer Service for support.

1. Your small kitchen appliance is warranted to the original purchaser to be free from any manufacturing defects under normal use and conditions for one (1) year, cord excluded. This Warranty applies only to the original purchaser of this product.
2. Retail stores/merchants selling this product do not have the right to alter, modify, or in any way revise the terms and conditions of the warranty.
3. If you use your appliance for household use and according to instructions, it should give you years of satisfactory service.
4. At its sole discretion, Maxi-Matic USA will either repair or replace the product found to be defective during the warranty period.
5. The repaired or replacement product will be in warranty for the remaining balance of the one-year warranty period and an additional one-month period.
6. Consumer's remorse is not an acceptable reason to return a product to our Service Center.
7. This limited warranty covers appliances purchased and used within the 50 U.S. states plus the District of Columbia and does NOT cover normal wear of parts or:
 - Damages caused by unreasonable use, neglect, normal wear and tear, commercial use, improper assembly or installation of product.
 - Damages caused in shipping.
 - Damages caused by replacement or resetting of house fuses or circuit breakers.
 - Defects other than manufacturing defects.
 - Breakage caused by misuse, abuse, accident, alteration, lack of proper care and maintenance, or incorrect current or voltage.
 - Lost or missing parts of the product. Parts will need to be purchased separately.
 - Damages of parts that are not electrical; i.e. cracked or broken plastic/glass, scratched/dented inner pots.
 - Damage from service or repair by unauthorized personnel.
 - Extended warranties purchased via a separate company or reseller.
 - Acts of God such as fire, floods, hurricanes, tornadoes, etc.
8. **This warranty does not apply to re-manufactured merchandise.**

Maxi-Matic, USA shall not be liable for any incidental or consequential damages caused by the breach of any express or implied warranty. Apart from the extent prohibited by applicable law, any implied warranty of merchantability or fitness for a particular purpose is limited in time to the duration of the warranty.

*One Year Limited Warranty valid only in the 50 U.S. states plus the District of Columbia, excluding Puerto Rico and the Virgin Islands.

This warranty is effective only if the product is purchased and operated in the USA; product usage which is in violation of the written instructions provided with the unit will void this warranty. For international warranty, please contact the local distributor.

This warranty gives you special legal rights and you may also have other rights to which you are entitled which may vary by state, province, and/or jurisdiction.

**Any instruction or policy included in this manual may be subject to change at any time.

MAXI-MATIC, USA

18401 E. Arenth Ave. City of Industry, CA 91748

Customer Support Hours of Operation MON-FRI 8:30 AM - 5:00 PM PST

(800) 365-6133 Ext: 120/107/105; (626) 912-9877 Ext: 120/107/105

Visit: **www.maxi-matic.com** for Live Chat Support and Contact Us Form

RETURN INSTRUCTIONS

RETURNS:

- A. Any return of defective merchandise to the manufacturer must be processed accordingly by first contacting customer service (info@maxi-matic.com) to obtain an RA # (Return Authorization Number). We will not accept any returns of merchandise without an applicable RA #.
- B. **IMPORTANT RETURN INSTRUCTIONS.** Your Warranty depends on your following these instructions if you are returning the unit to Maxi-Matic, USA:
 1. Carefully pack the item in its original carton or other suitable box with sufficient cushioning to avoid damage in shipping.
 2. Before packing your unit for return, be sure to enclose:
 - a) Your name, full address with zip code, daytime telephone number, and RA#,
 - b) A dated sales receipt or PROOF OF PURCHASE,
 - c) The model number of the unit and the problem you are having (Enclose in an envelope and tape directly to the unit before the box is sealed,) and
 - d) Any parts or accessories related to the problem.
 3. Maxi-Matic, USA recommends that you ship the package via UPS ground service for tracking purposes. **We cannot assume responsibility for lost or damaged products returned to us during incoming shipment.** For your protection, always carefully package the product for shipment and insure it with the carrier. C.O.D shipments cannot be accepted.
 4. **All return shipping charges must be prepaid by you.**
 5. Once your return has been received by our warehouse, Maxi-Matic, USA will repair or replace the product if it is defective in material or workmanship, subject to the conditions in paragraph B.
 6. **Maxi-Matic will pay the shipping charges to ship the repaired or replacement product back to you.**



cook's essentials®

Elite Customer Service Center

Mail: Maxi-Matic, USA
18401 E. Arenth Ave
City of Industry, CA
91748-1227

Phone: 800-365-6133 ext. 120/107/105

Website: www.maxi-matic.com
Visit our website for Live Chat Support
& Contact Us Form
Register your product online



[elitebymaximatic](https://www.facebook.com/elitebymaximatic)



[@elite_by_maximatic](https://www.instagram.com/@elite_by_maximatic)

Elite is a registered trademark of Maxi-Matic, USA.
Copyright Elite by Maxi-Matic.

Actual product may vary from the images/illustrations in this manual due to continual product improvement.

MODEL: K47615