

Shark® Air Purifier

HP070 Series

OWNER'S GUIDE



IMPORTANT SAFETY INSTRUCTIONS

HOUSEHOLD USE ONLY

⚠ WARNING

TO REDUCE THE RISK OF FIRE, ELECTRIC SHOCK, OR INJURY:

GENERAL WARNINGS

1. This appliance has a polarized plug (one blade is wider than the other). To reduce the risk of electric shock, this plug is intended to fit in a polarized outlet only one way. If the plug does not fit fully in the outlet, reverse the plug. If it still does not fit, contact a qualified electrician. Do not attempt to defeat this safety feature. Unplug or disconnect the appliance from the power supply before servicing.
2. **DO NOT** operate any unit with a damaged cord or plug. Discard the unit or return to an authorized service facility for examination and/or repair.
3. **DO NOT** run cord under carpeting. **DO NOT** cover cord with throw rugs, runners, or similar coverings. **DO NOT** route cord under furniture or appliances. Keep cord away from high traffic areas where it will not be tripped over.
4. If the power cord is damaged, it must be replaced by the manufacturer, its service agent, or similarly qualified persons in order to avoid a hazard.
5. This appliance should only be placed on flat and dry surfaces.
6. This appliance is not intended for use by anyone (including children) with reduced physical, sensory or mental capabilities, or lack of experience and knowledge, unless they have been given supervision or instruction concerning use of the appliance by a person responsible for their safety.
7. Children should be supervised to ensure that they **DO NOT** play with the appliance.
8. Cleaning and user maintenance shall not be made by children without supervision.
9. Prior to cleaning or other maintenance, the appliance must be unplugged from the electrical outlet.
10. **DO NOT** handle plug or appliance with wet hands.
11. **DO NOT** use without filter in place.
12. Only use Shark® branded filters and accessories.
13. **DO NOT** damage the power cord:
 - a) **DO NOT** pull or carry appliance by the cord or use the cord as a handle.
 - b) **DO NOT** unplug by pulling on cord. Grasp the plug, not the cord.
 - c) **DO NOT** stand the appliance on the power cord, close a door on the cord, pull the cord around sharp corners, or leave the cord near heated surfaces.
14. **DO NOT** use with any opening blocked; keep free of dust, lint, hair, and anything that may reduce airflow.
15. **DO NOT** use if airflow is restricted. If the air paths become blocked, turn the appliance off and unplug from electrical outlet. Remove all obstructions before you plug in and turn on the unit again.
16. **DO NOT** use if appliance is not working as it should, or has been dropped, damaged, left outdoors, or dropped into water.
17. **DO NOT** place appliance on unstable surfaces such as chairs or tables.
18. **DO NOT** use in the following areas:
 - a) Wet or damp surfaces
 - b) Outdoor areas
 - c) Spaces that are enclosed and may contain explosive or toxic fumes or vapors (lighter fluid, gasoline, kerosene, paint, paint thinners, mothproofing substances, or flammable dust)
19. Turn off all controls before plugging in or unplugging the appliance.
20. Unplug from electrical outlet when not in use and before any maintenance or cleaning.
21. Hand wash exterior/hard plastic/non-electronic parts with water only. Do not immerse. Cleaning with chemicals could damage the unit.
22. Make sure filter is in place after routine maintenance.
23. Not suitable for use with solid-state speed controls.
24. The appliance is only to be used with the power supply unit provided with the appliance.

ODOR NEUTRALIZER TECHNOLOGY

24. Observe the following when interacting with the Odor Neutralizer Technology cartridge.
 - a) **DO NOT** attempt to disassemble Odor Neutralizer Technology cartridge.
 - b) Avoid direct contact with the fragrance pod in the cartridge.
 - c) **DO NOT** directly inhale from the Odor Neutralizer Technology cartridge.
 - d) Keep away from children and pets.
 - e) Keep away from heat, sparks, and open flame.
 - f) **DO NOT** place in direct sunlight.
 - g) Avoid contact with fabrics and finished surfaces.

FRAGRANCE CARTRIDGE FIRST AID

- a) Eye contact: Remove contact lenses if present. Rinse continuously with water for several minutes
- b) Skin contact: Wash hands thoroughly after handling. If irritation or rash develops, seek medical advice/attention.
- c) Inhalation: Move person to fresh air if they are experiencing any respiratory symptoms. If symptoms persist, seek medical advice/attention.
- d) Ingestion: **DO NOT** induce vomiting. Seek medical advice/attention.

SAVE THESE INSTRUCTIONS

SETTING UP YOUR AIR PURIFIER

Parts:

1. Air Output Vents
2. Odor Neutralizer Technology Dial
3. Control Panel
4. Front Display
5. Air Purifier Body
6. Air Intake Vents
7. Mesh Dust Filter
8. HEPA Filter
9. HEPA Filter Door



TIPS FOR SETTING UP YOUR AIR PURIFIER

- Make sure the front panel of the air purifier faces away from the closest wall.
- Do not move the unit while it is running. Turn off the power and unplug the air purifier before moving it.
- Make sure the air intake vents are not blocked.
- Do not place anything on the air purifier.
- Do not place the air purifier near heaters or radiators.
- Keep the air purifier out of direct sunlight and away from water or other liquid.
- Keep all nearby doors and windows closed when operating the air purifier.
- Avoid using in very humid environments.



1. **DO NOT** plug in the air purifier. First, carefully turn the air purifier upside down and place it on a level floor surface. Rotate the filter door counterclockwise to unlock it, then lift it off to access the HEPA filter.



2. Take the HEPA filter out of its plastic packaging. Reinstall the HEPA filter in either orientation.



3. With the HEPA filter reinstalled, rotate the filter door clockwise until it clicks into place.

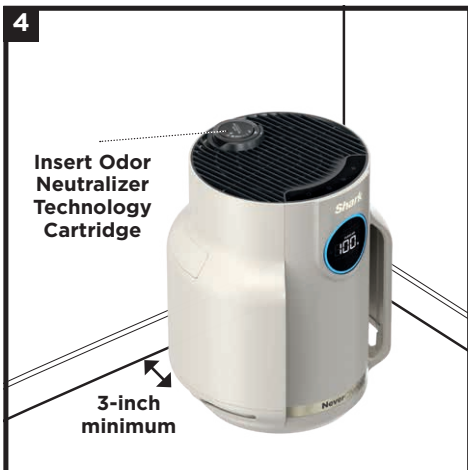

4. Set up the air purifier on a level surface, at least 3 inches (8 cm) from walls and objects.
Find the Odor Neutralizer Technology cartridge and follow the instructions to install it.

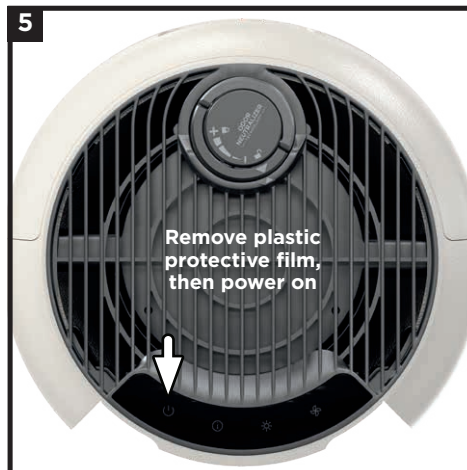

5. Carefully remove the yellow sticker on the front of the air purifier to access the display panel.
Plug the air purifier into an electrical outlet and press the power button on the top control panel.



6. When the power is on, the air purifier will begin to analyze the air quality, indicated by the rotating lights.
After a few seconds, the air purifier will display the current air quality.
If the air quality is between 96% to 100%, the number on the display will spin every five minutes to indicate that the machine is actively monitoring and cleaning the air.

Note: This unit can operate independently without an Odor Neutralizer Technology cartridge. The use of Odor Neutralizer Technology is optional.

Note: NeverChange HEPA Filter Technology allows up to 5 years* of use from a single HEPA filter.

*Tested to GB/T18801-2015 P.CCM, based on 50% CADR declined, 52 sq. ft. cleaning area and 12 hours daily operation on MAX fan speed.

CONTROL PANEL

There is a control panel on the top of the air purifier and a display screen on the front.

TOP CONTROL PANEL

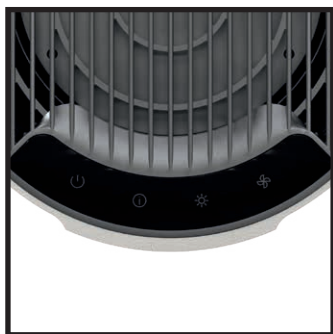





FRONT DISPLAY SCREEN



Displays the current air quality status based on the Air Info mode selected on the top control panel.

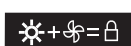

TOP CONTROL PANEL BUTTONS





-  **On/Off:** Press to turn the power on or off.
-  **Fan Speed:** Press repeatedly to cycle through the fan speed options: A Auto, 1 Quiet, 2 Low, 3 Medium, 4 High, 5 Maximum. For optimal filter life and performance, select Auto mode by cycling through the speed levels until the A indicator appears. In Auto mode, the fan speed automatically adjusts: as air quality improves, fan speed decreases. If air quality worsens, fan speed will increase. For tips and more information, see the Optimizing Fan Speed section.
-  **Air Info:** Press to switch between air quality display options and filter life information. See Mesh Dust Filter Maintenance section for more information on dust filter, or Air Info Settings section for more information on air quality.
-  **Brightness:** Adjusts the brightness of both the front display screen and the top control panel. Switch between 3 options: full brightness, partially dim, fully dim. In fully dim mode, the air purifier will continue to run with the LED light off—perfect for nighttime.
-  **Child Lock:** Press and hold the Brightness and Fan speed buttons at the same time for two seconds to lock the top control panel buttons. To unlock, press and hold both buttons again for two seconds.

Tips and Tricks:

-  **Optimize Performance in Eco Mode:** After 100% clean air status is achieved for 5 minutes in Auto Mode, your air purifier will enter Eco Mode. Your unit's filter life will be optimized.
-  **Turn Off Beeping:** To turn off notification sounds, press and hold the Air Info and Fan Speed buttons at the same time for two seconds. To resume, press and hold both buttons again.

AIR INFO SETTINGS

The built-in sensor detects your air quality to give you real-time information. Use the **AIR INFO** button  to switch between air quality display options.

INFO	FRONT DISPLAY SCREEN	REAL-TIME READING
% CLEAN AIR		Displays the air quality rating: <ul style="list-style-type: none"> • Poor: 0%–69% • Fair: 70%–84% • Good: 85%–100% % CLEAN AIR uses particulate matter (PM) air quality standards as determined by the EPA to calculate the air quality rating.
PARTICLE SIZES		The PM (particulate matter) value is the amount of particulate in your air, measured in micrograms (µg) per cubic meter. Your air purifier measures three particle sizes, PM1, PM2.5, and PM10.
PM1		Displays the number of PM1-sized particles in your air, including ultra-fine allergens.* *Allergens refers to non-living matter.
PM2.5		Displays the number of PM2.5-sized particles in your air, including smoke.
PM10		Displays the number of PM10-sized particles in your air, including dust and pollen.

UNDERSTANDING YOUR AIR QUALITY

The rings on the front display will change color as your air quality changes, allowing you to easily monitor your air quality even when the air purifier is across the room.

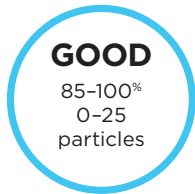

A blue ring means your air quality is good, with a low level of particle concentration.

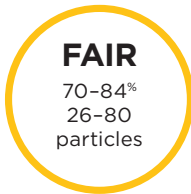

An amber ring means your air quality is fair, with a moderate level of particle concentration. For better results, increase fan speed or select Auto Mode.

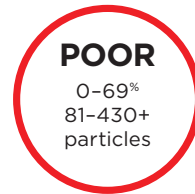

A red ring means your air quality is poor, with a high level of particle concentration. For better results, increase fan speed or select Auto Mode.

Note: The air quality sensor uses a cumulative particle count across all particle sizes to determine percentage of clean air.

OPTIMIZING FAN SPEED

Your air purifier has 5 speed settings plus Auto Mode. Adjust fan speed to optimize your cleaning performance.

DISPLAY	SPEED	BEST FOR
	AUTO	Optimizing HEPA filter life
	1-2	Quiet operation
	3-4	Reducing odors
	5 (MAX)	Maximum purification and debris capture

TROUBLESHOOTING AND FREQUENTLY ASKED QUESTIONS

Product	What are the recommended settings?	We recommend using this air purifier in Auto Mode. Auto Mode leverages your air purifier's particle sensor, and this adjusts the fan speed automatically. Higher fan speeds work best for reducing odors and capturing debris most effectively.
	Where should I set up my air purifier?	We recommend setting up the air purifier in the room of your home where there is the most activity. This will help to clear the air of pollutants and odors as they are introduced. Note: This model is recommended for smaller rooms.
	What is Eco mode?	After 100% clean air is achieved for 5 minutes in Auto Mode, your air purifier will enter Eco Mode. The fan will turn off until a significant number of particles are detected, optimizing your HEPA filter's life.
	Can I mute the air purifier, so it doesn't beep when pressing the buttons?	To turn off notification sounds, press and hold the Air Info ⓘ and Fan Speed ⚙ buttons at the same time for two seconds. To reactivate sounds, press and hold both buttons for 2 seconds again.
	Why are the top control panel buttons not working?	Your air purifier may have the child lock setting activated. Press and hold the Brightness ✨ and Fan Speed ⚙ button for two seconds to turn this setting on or off.
Air Quality	Why is my air quality always at 100%?	If your air purifier displays a blue ring, your air quality is good. However, air quality will fluctuate as you introduce pollutants into your home. Activities like smoking, cooking, dusting, or spraying cleaning products (among other things) can add pollutants to your air. Our Clean Sense IQ™ technology tracks this fluctuation in real time and adjusts as it detects particles. To determine if the sensor is working correctly, spray perfume or aerosol cleaning product near the sensor on the back of the air purifier. Please visit sharkclean.com/support for more information.
	Why is my air quality never at 100%? Why is my air quality always at 0%?	If your air quality never reaches 100%, make sure that the HEPA filter is properly installed and that its original plastic packaging has been removed. Activities like smoking, burning candles, running a humidifier, opening windows, and cooking (among other things) can add more pollutants to your air. Make sure to survey your environment and remove anything that could be causing low air quality. If the problem persists after these checks, the air quality sensor on the back of the air purifier may be dirty, causing a false reading. First, turn off and unplug the unit. Remove the mesh dust filter to locate the sensor on the back. Use a hand vacuum or hose attachment to clean the area around the sensor. After cleaning, wait 30 seconds before plugging the unit back in and turning it on. Let it run for 24 hours and monitor the air quality.
Mesh Dust Filter	What is the mesh dust filter for?	This easy-to-clean mesh dust filter captures large debris like hair, dust, and lint to protect the 3-layer HEPA filter. Maintenance is required on this filter when indicated on the front display. Refer to the Mesh Dust Filter Maintenance section for more information.
	How do I know when to clean the pre-filter?	When the mesh dust filter needs maintenance, the front display will show a pulsing red ring along with the text "check dust filter." Refer to the Mesh Dust Filter Maintenance section for more information.
HEPA Filter	Can I wash the HEPA filter?	No, the HEPA filter is not washable. Keep filter away from water and dispose of it when it is dirty.

Customer Service

For further assistance, call 1-855-523-4061.

Checking the Mesh Dust Filter:

When the mesh dust filter needs maintenance, the front display will show the following screen with a pulsing red ring:



Cleaning the Mesh Dust Filter:

When the Check Dust Filter message appears on the front display, remove the dust filter and inspect it for debris. If maintenance is required, be sure to **KEEP THE AIR PURIFIER PLUGGED IN** and running, and complete the following steps:



1. LOCATE AND REMOVE MESH DUST FILTER

Gently slide up the filter and remove it. Check the screen for dust and debris buildup.



2. CLEAN DUST FILTER

Use a **vacuum cleaner** on low speed with a soft brush attachment OR a **cloth/towel** to remove debris from the mesh screen. **DO NOT use abrasive chemical cleaners.**

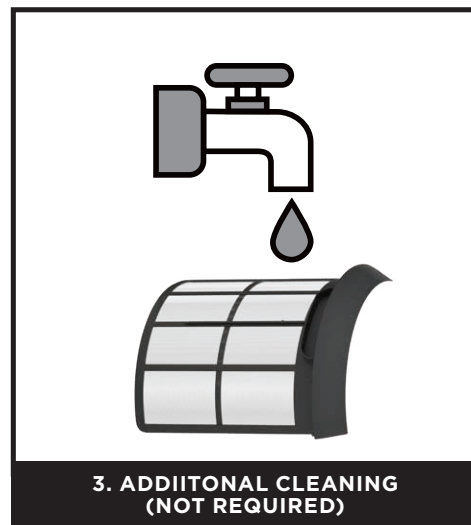

3. ADDITIONAL CLEANING (NOT REQUIRED)

If additional cleaning is required, rinse the mesh dust filter with room temperature tap water. Be sure to completely dry the screen for 12 hours before reinstalling. **DO NOT USE** the air purifier when mesh filter is wet.



4. REINSTALL MESH DUST FILTER

Gently reinsert the mesh dust filter into the slot on the side of the air purifier. Be sure to push the dust filter into place until it is flush with the air purifier body.



5. RECALIBRATION

Once the filter has been cleaned and reinstalled, the air purifier will recalibrate and begin to analyze air quality, indicated by the rotating lights.

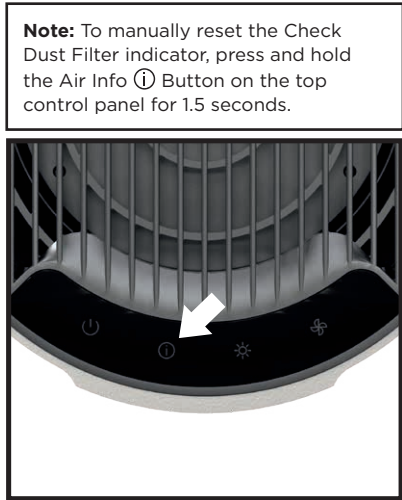

Note: To manually reset the Check Dust Filter indicator, press and hold the Air Info (i) Button on the top control panel for 1.5 seconds.

Note: NeverChange HEPA Filter Technology allows up to 5 years* of use from a single HEPA filter.
 *Tested to GB/T18801-2015 P.CCM, based on 50% CADR declined, 52 sq. ft. cleaning area and 12 hours daily operation on MAX fan speed.

MAINTAINING YOUR AIR PURIFIER

NOTE: Unplug the air filter whenever doing any cleaning or maintenance (other than checking the mesh dust filter.)

Exterior Cleaning:

For best results, clean the exterior every two months or as needed. Use a microfiber cloth to remove dust. To clean, wipe down the exterior with a microfiber cloth dampened with warm, soapy water. Avoid excess water and abrasive chemical cleaners to prevent damage.



Interior Cleaning:

For best results, clean the interior of the air purifier every two months or as needed. Remove the filter door, take out the HEPA filter, and use a vacuum cleaner or a microfiber cloth to remove dust and debris from the interior. **DO NOT** use abrasive chemical cleaners or water on the inside of the air purifier.



ODOR NEUTRALIZER TECHNOLOGY

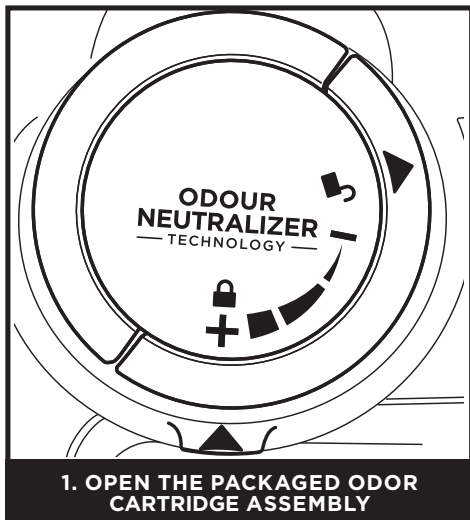

1. OPEN THE PACKAGED ODOR CARTRIDGE ASSEMBLY

Remove the odor cartridge assembly from the cardboard box and aluminum bag.

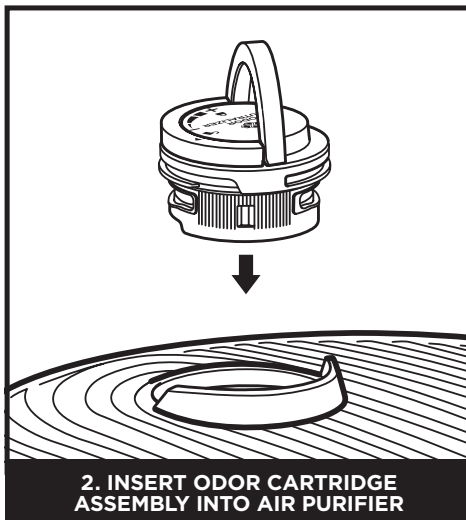

2. INSERT ODOR CARTRIDGE ASSEMBLY INTO AIR PURIFIER

Flip up the handle on the odor dial, align the arrows, then insert the assembly into the air purifier.

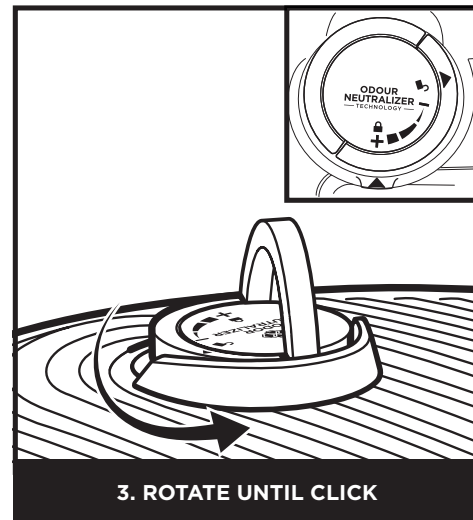

3. ROTATE UNTIL CLICK

To lock and engage the odor cartridge assembly, rotate it counterclockwise until it clicks at least once. Continue to rotate the dial toward the high position to increase the intensity.

SETTINGS

Settings: The Odor Neutralizer Technology dial has 4 intensity settings: Low, Medium, High, and Off.

ODOR DIAL POSITION	CLICKS	SETTING	RECOMMENDED FOR
	1	OFF	<ul style="list-style-type: none"> When you are not actively looking to reduce odors. This will extend the life of the odor cartridge.
	2	LOW	<ul style="list-style-type: none"> Mild odor events such as trash smells. Small spaces like a bathroom or entryway.
	3	MEDIUM	<ul style="list-style-type: none"> Strong odor events such as cooking or pet smells. Mid-sized spaces like a bedroom or kitchen.
	4	HIGH	<ul style="list-style-type: none"> Optimal odor-reducing performance. Extreme odor events such as smoke or lingering burnt smells. Large spaces like a living room or multiple rooms.

Note: Adjusting the fan speed is another way to control Odor Neutralizer Technology intensity. See the Optimizing Fan Speed section for more information.

LOW
Rotate the dial to the Low position to decrease intensity to the lowest level when in use.

HIGH
Rotate the dial to the High position to increase intensity to the highest level when in use.

TIPS

Odor Cartridge Removal

- Remove the odor cartridge from the dial if you don't want to use Odor Neutralizer Technology.
- To remove the cartridge, flip up the handle and rotate the odor dial clockwise until the two arrows are aligned. Pull the handle to remove the dial and access the cartridge.

Maintenance Required

- Replace the cartridge as recommended under Odor Cartridge Replacement.
- Visit qr.sharkclean.com/odortech to learn more and purchase replacements.

Fragrance Strength Over Time

- The intensity of the Odor Neutralizer Technology's fragrance may diminish over time. It may also have no noticeable fragrance at all. This is natural and does not indicate that the technology is not working. Follow replacement instructions to ensure continued performance.

ODOR NEUTRALIZER TECHNOLOGY REPLACEMENT

NOTE: This unit can operate independently without an Odor Neutralizer Technology device; the use of Odor Neutralizer Technology is optional.

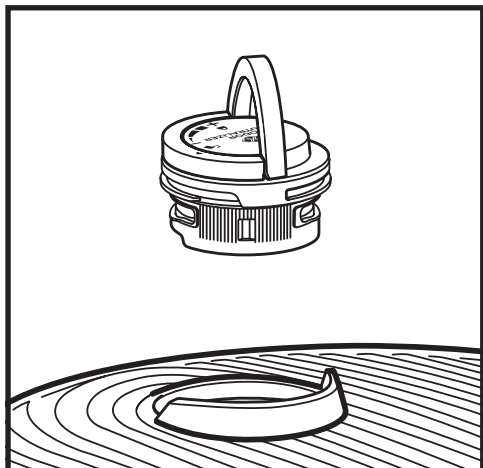

1. REMOVE THE ODOR CARTRIDGE ASSEMBLY

Flip up the handle and rotate the dial counterclockwise until the two arrows are aligned. Pull the handle to remove the dial from the air purifier.

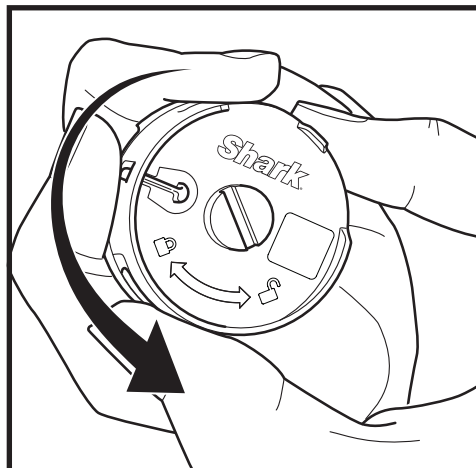

2. REMOVE OLD ODOR CARTRIDGE

Rotate the cartridge counterclockwise in the dial housing and pull out the cartridge to remove it.

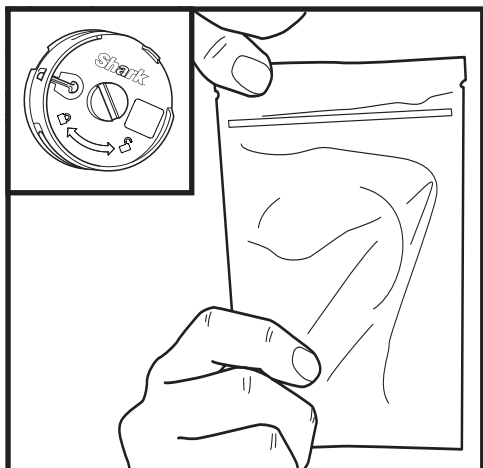

3. REMOVE NEW CARTRIDGE FROM BAG

Remove the new odor cartridge from the sealed packaging. To maintain the life of the cartridge, keep it in the sealed packaging until you are ready to install it.

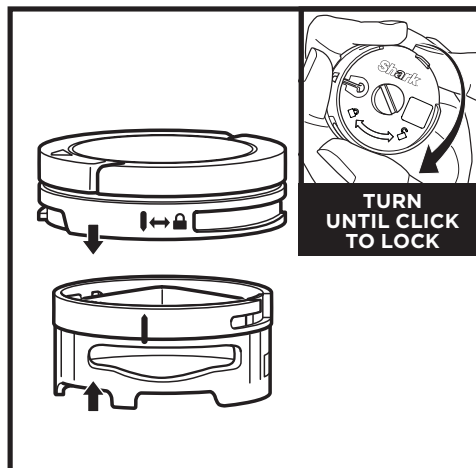

4. INSTALL NEW CARTRIDGE IN DIAL

Align the yellow arrow on the side of the cartridge with the yellow arrow on the side of the dial cover, then insert the cartridge into the dial. Rotate the cartridge clockwise to lock it in place.

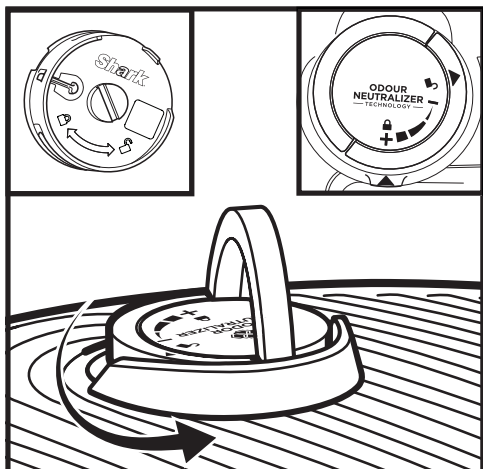

5. INSTALL THE ODOR DIAL ASSEMBLY

Align the arrow on the dial cover with the arrow on the air purifier, then reinsert the dial into the air purifier. Rotate the dial counterclockwise until it clicks into an intensity setting to engage. Rotate further to change the intensity setting.

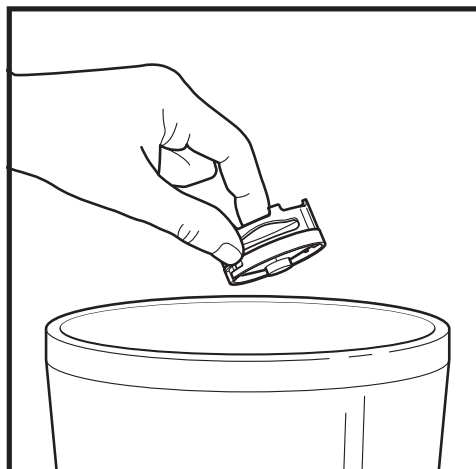

6. USED CARTRIDGE DISPOSAL

Dispose of the old cartridge by dropping it into the trash.

Note: Odor cartridges should be replaced every 3 months or as needed for optimal Odor Neutralizer Technology performance.

ORDER ADDITIONAL ACCESSORIES AND REPLACEMENT FILTERS

Additional accessories and replacement filters are available on sharkaccessories.com



Odor Neutralizer Technology Cartridges (2)

Two replacement cartridges that guard against bad odors to help freshen your home. We recommend replacing cartridges every 3 months or as needed in your air purifier. Odor Neutralizer Technology intensity dial sold separately.

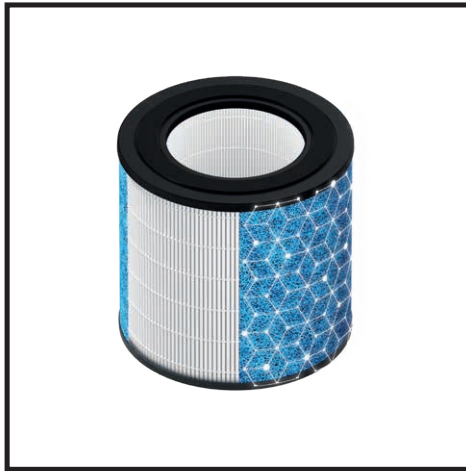

Shark NeverChange® Anti-Allergen True HEPA Filter

Captures 99.98%* of large, small, and micro-sized particles from the air and is equipped with 240 ± 10g virgin carbon for heightened protection against household odors.

*Based on IEST-RPCC007.3, 0.1-0.2 microns.

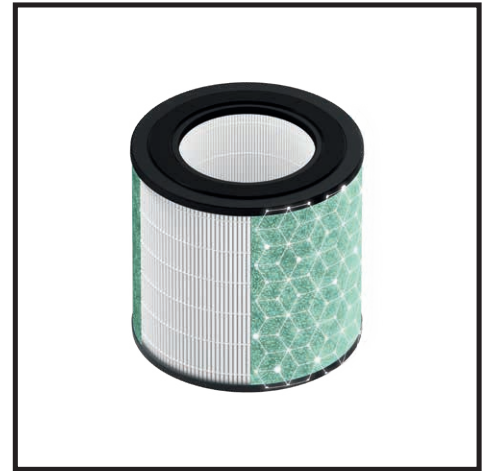

Shark NeverChange PetPro filter

Captures 99.98%* of large, small, and micro-sized particles from the air and is equipped with 90 ± 10g virgin carbon for heightened protection against household odors. Contains 25% more carbon for odor absorption**.

*Based on IEST-RPCC007.3, 0.1-0.2 microns.

**Compared to the Shark NeverChange Anti-Allergen True HEPA Filter.

TWO (2) YEAR LIMITED WARRANTY

The Two (2) Year Limited Warranty applies to purchases made from authorized retailers of **SharkNinja Operating LLC**. Warranty coverage applies to the original owner and to the original product only and is not transferable.

SharkNinja warrants that the unit shall be free from defects in material and workmanship for a period of two (2) years from the date of purchase when it is used under normal household conditions and maintained according to the requirements outlined in the Owner's Guide, subject to the following conditions and exclusions:

CA RESIDENTS ONLY:

The Two (2) Year Limited Warranty period begins on the original date of delivery or pickup.

What is covered by this warranty?

1. The original unit and/or non-wearable parts deemed defective, in SharkNinja's sole discretion, will be repaired or replaced up to two (2) years from the original purchase date.
2. In the event a replacement unit is issued, the warranty coverage ends six (6) months following the receipt date of the replacement unit or the remainder of the existing warranty, whichever is later. SharkNinja reserves the right to replace the unit with one of equal or greater value.

What is not covered by this warranty?

1. Normal wear and tear of wearable parts (such as filters), which require regular maintenance and/or replacement to ensure the proper functioning of your unit, are not covered by this warranty. Replacement parts are available for purchase at sharkaccessories.com.
2. Any unit that has been tampered with or used for commercial purposes.
3. Damage caused by misuse, abuse, negligent handling, failure to perform required maintenance (e.g., not replacing the filters), or damage due to mishandling in transit.

4. Consequential and incidental damages.
5. Defects caused by repair persons not authorized by SharkNinja. These defects include damages caused in the process of shipping, altering, or repairing the SharkNinja product (or any of its parts) when the repair is performed by a repair person not authorized by SharkNinja.
6. Products purchased, used, or operated outside North America.

How to get service

If your appliance fails to operate properly while in use under normal household conditions within the warranty period, visit sharkclean.com/support for product care and maintenance self-help. Our Customer Service Specialists are also available at **1-855-523-4061** to assist with product support and warranty service options, including the possibility of upgrading to our VIP warranty service options for select product categories. So we may better assist you, please register your product online at registeryourshark.com and have the product on hand when you call.

SharkNinja will cover the cost for the customer to send in the unit to us for repair or replacement. A fee of \$25.95 (subject to change) will be charged when SharkNinja ships the repaired or replacement unit.

How to initiate a warranty claim

You must call **1-855-523-4061** to initiate a warranty claim. You will need the receipt as proof of purchase. We also ask that you register your product online at registeryourshark.com and have the product on hand when you call, so we may better assist you. A Customer Service Specialist will provide you with return and packing instruction information.

How state law applies

This warranty gives you specific legal rights, and you also may have other rights that vary from state to state. Some states do not permit the exclusion or limitation of incidental or consequential damages, so the above may not apply to you.

IMPORTANT INFORMATION

REGISTER YOUR PURCHASE



registeryourshark.com



Scan QR code using mobile device

RECORD THIS INFORMATION

Model Number: _____

Serial Number: _____

Date of Purchase: _____
(Keep receipt)

Store of Purchase: _____

TECHNICAL SPECIFICATIONS

Voltage: 24V DC / 0.8A

Watts: 16W

Benefits of registering your product and creating an account:

- Get easier, faster product support and access to warranty information
- Access troubleshooting and product care instructions
- Be among the first to know about exclusive product promotions

TIP: You can find the model and serial numbers on the QR code label on the bottom of the unit.

PLEASE READ CAREFULLY AND KEEP FOR FUTURE REFERENCE.

This Owner's Guide is designed to help you get a complete understanding of your new Shark® Air Purifier.

SharkNinja Operating LLC
US: Needham, MA 02494
CAN: Ville St-Laurent, QC H4S 1A7

1-800-798-7398
sharkclean.com

Illustrations may differ from actual product. We are constantly striving to improve our products; therefore the specifications contained herein are subject to change without notice.

This product may be covered by one or more U.S. patents. See sharkninja.com/patents for more information.



FCC WARNINGS

Note: This unit has been tested and found to comply with FCC limits for Class B digital devices. These limits are designed to provide reasonable protection against harmful interference in a residential installation. This unit generates, uses, and can radiate radio frequency energy, and if not installed and used in accordance with the instructions, may cause harmful interference to radio communications.

This device complies with part 15 of the FCC Rules. Operation is subject to the following two conditions: (1) this device may not cause harmful interference, and (2) this device must accept any interference received, including interference that may cause undesired operation.

To see if this unit interferes with radio or television reception, try turning it off and on.

To correct any interference:

- Reorient or relocate the receiving antenna.
- Increase the distance between the unit and the receiver.
- Connect the unit to a different outlet than the receiver.
- Consult the dealer or an experienced technician for help.

Caution: Any changes or modifications to this unit not expressly approved by the party responsible for compliance could void the user's authority to operate it.