

Shark

CYCLONE™

CH700 SERIES



Scan here with smartphone camera for more detailed instructions.

IMPORTANT SAFETY INSTRUCTIONS - SAVE THESE INSTRUCTIONS

WARNING: TO REDUCE THE RISK OF INJURY, USER MUST READ INSTRUCTION MANUAL • HOUSEHOLD USE ONLY

WARNING

To reduce the risk of injury, fire, electric shock, and property damage resulting from improper use of the appliance, carefully observe the following instructions. This unit contains electrical connections and moving parts that potentially present risk to the user.

POWER SUPPLY, CHARGING ADAPTER, AND VACUUM CONTAIN ELECTRICAL CONNECTIONS. WHEN USING AN ELECTRICAL APPLIANCE, BASIC PRECAUTIONS SHOULD ALWAYS BE FOLLOWED, INCLUDING THE FOLLOWING:

1. There are **NO** serviceable parts.
2. **DO NOT** use to vacuum any liquids.
3. **DO NOT** immerse in water or other liquids.
4. If vacuum is damaged, discontinue use.
5. To avoid fire, explosion, or injury, inspect vacuum and charging dock for any damage before use. **DO NOT** use damaged vacuum or charging dock.
6. **DO NOT** use outdoors or on wet surfaces. Use only on dry surfaces.
7. If vacuum cleaner is not working as it should, or has been dropped, damaged, left outdoors, or immersed in water, return it to SharkNinja for examination, repair, or adjustment.
8. **DO NOT** handle charger or vacuum cleaner with wet hands.
9. **DO NOT** leave vacuum cleaner unattended while powered on.
10. Keep vacuum away from heated surfaces.
11. Always turn off vacuum before connecting charging adapter.
12. **DO NOT** incinerate appliance, even if it is severely damaged, as lithium-ion battery may explode in a fire.
13. Use only with Listed/Certified Information Technology (Computer) Equipment, Listed/Certified ITE Power Supply, or Listed Class 2 Power Unit.

GENERAL USE

14. **DO NOT** carry the charger by the cord or yank to disconnect from an outlet; instead grasp the plug and pull to disconnect.
15. Keep charger cord away from heated surfaces.
16. Use only as described in this manual.
17. Keep your work area well lit.
18. To avoid unintentional starting, always turn off the vacuum cleaner before picking it up or carrying it, and before attaching or detaching the charger, dust cup, filter, or any accessories.
19. **DO NOT** put any objects into openings.
20. **DO NOT** use if any opening is blocked; keep free of dust, lint, hair, or anything that may reduce airflow.
21. **DO NOT** use without dust cup and filter in place.
22. Persons with reduced physical, sensory, or mental capabilities may only use the vacuum with supervision or prior safety instruction and an understanding of the hazards involved. Children may not clean or maintain the vacuum

without supervision. This vacuum is not a toy.

23. **DO NOT** use if airflow is restricted; if the air paths become blocked, turn off the vacuum cleaner. Clear all obstructions and power on again.
24. Keep nozzle away from hair, face, fingers, uncovered feet, or loose clothing.
25. Only use manufacturer's recommended attachments.
26. **DO NOT** charge at temperatures below 50°F (10°C) or above 104°F (40°C). Charging improperly or at temperatures outside of the specified range may damage the battery and increase the risk of fire.
27. Store the appliance indoors. **DO NOT** use or store it below 37.4°F (3°C). Ensure the appliance is at room temperature before operating.

DUST CUP/FILTER/ACCESSORIES

Before turning on the vacuum:

28. Make sure filter is thoroughly dry after routine cleaning.
29. Make sure dust cup and filter are in place after routine maintenance.
30. Make sure accessories are free of blockages and keep openings away from face and body.
31. Use only Shark brand filters and accessories.

GENERAL CLEANING

32. **DO NOT** vacuum up hard or sharp objects such as glass, nails, screws, or coins that could damage the vacuum cleaner.
33. **DO NOT** vacuum up drywall dust, fireplace ash, or embers.
34. **DO NOT** use as an attachment to power tools for dust collection.
35. **DO NOT** vacuum up smoking or burning objects such as hot coals, cigarette butts, or matches.
36. **DO NOT** vacuum up flammable or combustible materials (e.g., lighter fluid, gasoline, or kerosene) or use vacuum in areas where they may be present.
37. **DO NOT** vacuum up toxic solutions (e.g., chlorine bleach, ammonia, or drain cleaner).
38. **DO NOT** use in an enclosed space where vapors are present from paint, paint thinner, moth-proofing substances, flammable dust, or other explosive or toxic materials.
39. **DO NOT** immerse vacuum cleaner in water or other liquids.
40. Use extra care when cleaning on stairs.

LITHIUM-ION BATTERY

41. The battery is the power source for the appliance. **DO NOT** carry the appliance with your finger on the power button. **DO NOT** charge appliance with the power on.
42. Charge with USB-C connection or Dongguan Yinli Electronics Co., Ltd. YLJXA-T050200 charger. Using unapproved sources may cause risk.
43. Use appliance only with included lithium-ion battery. Use of any other battery may create a risk of injury and fire.
44. Under abusive conditions, liquid may be ejected from the battery. Avoid contact with liquid, as it may cause irritation or burns. If contact occurs, flush with water. If liquid contacts eyes, seek medical help.
45. Store the appliance indoors. To maintain battery life, **DO NOT** use or store battery at temperatures below 37.4°F (3°C) or above 104°F (40°C).
46. **DO NOT** expose appliance to fire or temperature above 266°F (130°C) as it may cause explosion.
47. There are **NO** serviceable parts. To ensure safety, **DO NOT** modify or attempt to repair the appliance.
48. **DO NOT** use a battery pack or appliance that is damaged or modified. Damaged or modified batteries may exhibit unpredictable behavior resulting in fire, explosion, or risk of injury.

FEATURES

- A** Air-Intake Nozzle
- B** Dust Cup Release Button
- C** Filter
- D** Charging Indicator Light
- E** On/Off Switch
- F** Vacuum Body
- G** USB-C Charger
- H** Detachable Charger*
- I** Integrated Charger*
- J** Upholstery Tool*
- K** Crevice Tool*

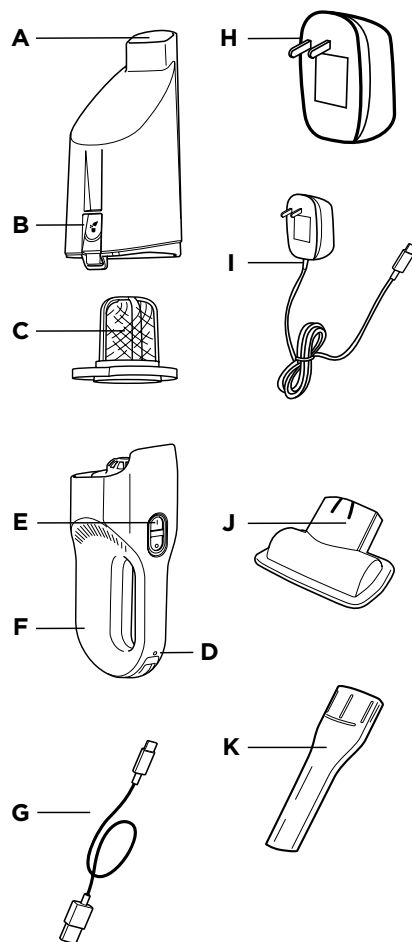

*For additional accessories available, please visit sharkaccessories.com

CHARGING YOUR SHARK® VACUUM

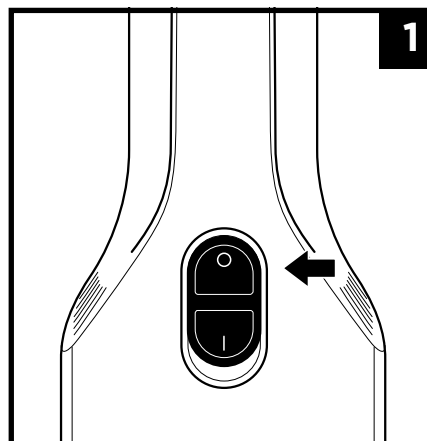

1. Make sure to switch the unit into the "O" position to power off before charging.

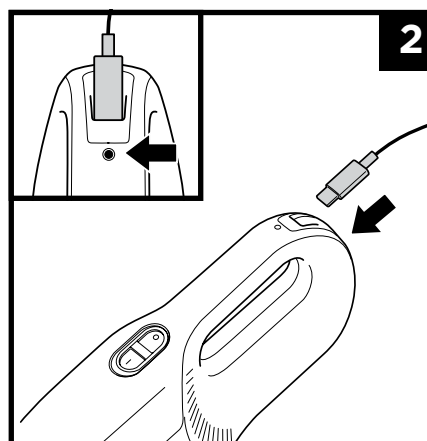

2. Plug the USB-C end of the charging cord into the port on the handle. Plug the charging block into a wall outlet.

NOTE: Lithium-ion battery takes approximately 3 hours to charge completely.

USING YOUR SHARK® VACUUM

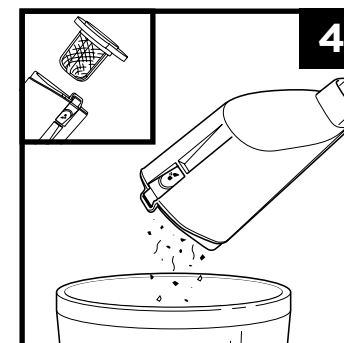
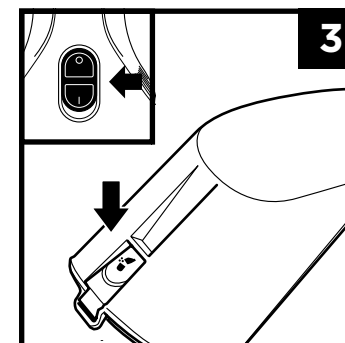
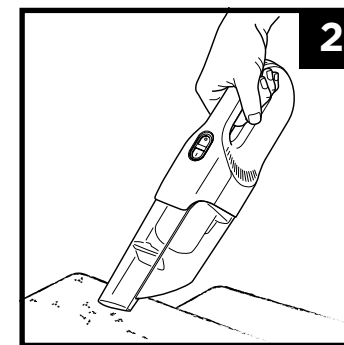
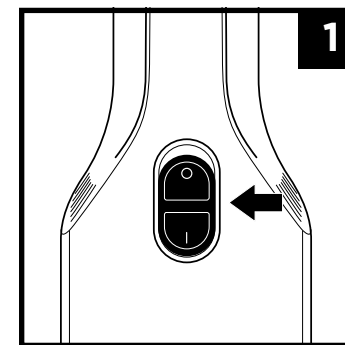

1. Slide the switch into "I" position to power on.
2. Run the nozzle over the surface to be cleaned.
3. To empty the dust cup, first slide the switch into "O" position to power off. Then press the dust cup release button on the back of the hand vac and pull off the dust cup.
4. Remove the filter from the dust cup by pulling the tab in the center and then empty the debris into the trash.
5. Once debris is emptied, place the filter back in place and reattach the dust cup.

ACCESSORIES

INSERTION AND REMOVAL

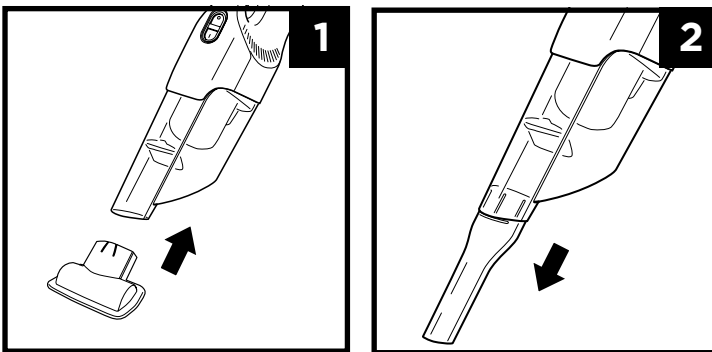

1. To install an accessory, align it with the nozzle, then slide it on.
2. To remove an accessory, slide it straight off the nozzle.

TROUBLESHOOTING

Problem	Solution
The vacuum will not operate	Battery needs to be recharged. Lithium-ion battery takes approximately 3 hours to charge completely. Try using a different electrical outlet to charge.
Vacuum will not pick up or suction is weak	Dust cup is full. Empty the dust cup. The filter needs to be cleaned or replaced. Vacuum needs to be recharged.
Dust is escaping from the vacuum	Empty the dust cup. The filter may be installed incorrectly. Remove the filter, then reinstall it correctly. Check the filter for holes or punctures. The filter will need to be replaced if there is a hole or puncture. An obstruction may be blocking the dust cup lid, keeping it from closing correctly. Clear any obstructions and ensure the lid is completely closed.

BATTERY INDICATOR

Pulsing Light	Low Battery	If the power switch is in the (I) position but the power doesn't turn on and the battery indicator light on the hand vac is pulsing, this means the battery power is too low. Slide the power switch to the (O) position and charge the battery before using the vacuum.
Pulsing Light (while plugged in)	Vacuum Charging	To charge the vacuum, connect charging cord to unit and plug into wall outlet. The light will turn off when the unit is fully charged.
No Light	Fully Charged	When the vacuum is fully charged, the indicator light will turn off. (It takes approximately 3 hours for a full charge).

REGISTER YOUR PURCHASE



This equipment has been tested and found to comply with the limits for a Class B digital device, pursuant to part 15 of the FCC Rules. These limits are designed to provide reasonable protection against harmful interference in a residential installation. This equipment generates, uses, and can radiate radio frequency energy and, if not installed in accordance with the instructions, may cause harmful interference to radio communications. However, there is no guarantee that interference will not occur in a particular installation. If this equipment does cause harmful interference to radio or television reception, which can be determined by turning the equipment off and on, the user is encouraged to try to correct the interference by one or more of the following measures:

- 1 Reorient or relocate the receiving antenna.
- 2 Increase the separation between the equipment and receiver.
- 3 Connect the equipment into an outlet on a circuit different from that to which the receiver is connected.
- 4 Consult the dealer or an experienced radio/TV technician for help.

This Device complies with part 15 of the FCC rules. Operation is subject to the following conditions:

- 1 This device may not cause harmful interference.
- 2 This device must accept any interference received, including interference that may cause undesired operation.

Changes or modifications not expressly approved by the party responsible for compliance could void the user's authority to operate this device.

MAINTENANCE

CLEANING THE DUST CUP

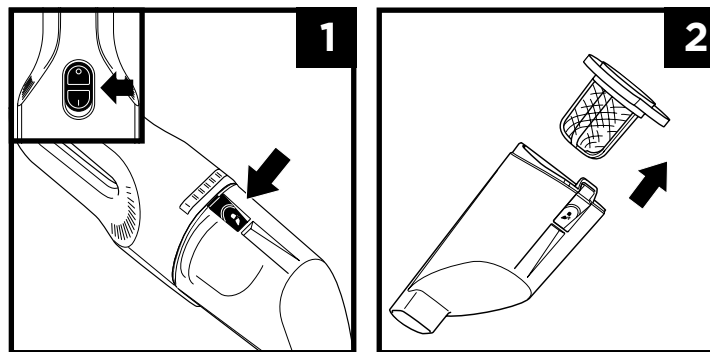

1. Slide the switch to the "O" position to power off. Press the dust cup release button and pull out the dust cup.
2. Carefully take the filter frame out of the dust cup and remove the filter.

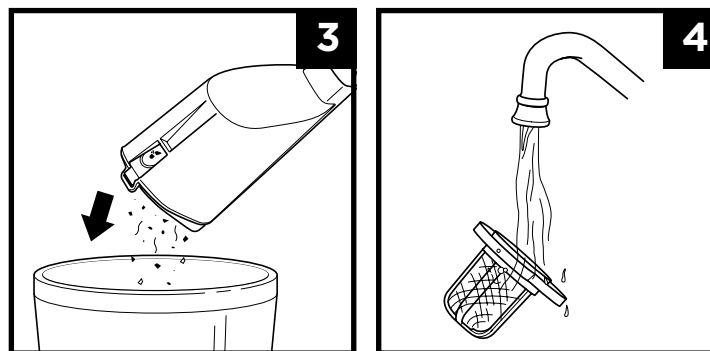

3. Empty the dust cup into the trash.
4. Hand-rinse the filter in cold water and let it air-dry for at least 24 hours before reinstalling. Air-dry only. **DO NOT** use a hair dryer or clothes dryer.

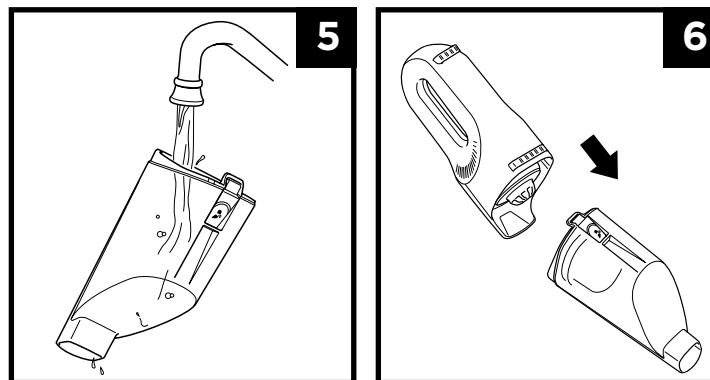

5. To clean the interior of the dust cup, rinse it with water. Place it on its side with the lid open to air-dry for at least 24-48 hours before reinstalling.
6. When the filter is dry, reinstall into the dust cup, then reattach the dust cup to the main body.

DO NOT wash any parts or accessories in a dishwasher.

NOTE: For best results, replace the filter every 6 to 9 months.

TECHNICAL SPECIFICATIONS

CH700 Series: 7.2V \approx

Charging Adapter part number:
XCHRGCH700

TWO-YEAR LIMITED WARRANTY

The Two (2) Year Limited Warranty applies to purchases made from authorized retailers of **SharkNinja Operating LLC**. Warranty coverage applies to the original owner and to the original product only and is not transferable.

SharkNinja warrants that the unit shall be free from defects in material and workmanship for a period of two (2) years from the date of purchase when it is used under normal household conditions and maintained according to the requirements outlined in the Owner's Guide, subject to the following conditions and exclusions:

What is covered by this warranty?

1. The original unit and/or non-wearable components deemed defective, in SharkNinja's sole discretion, will be repaired or replaced up to two (2) years from the original purchase date.
2. In the event a replacement unit is issued, the warranty coverage ends six (6) months following the receipt date of the replacement unit or the remainder of the existing warranty, whichever is later. SharkNinja reserves the right to replace the unit with one of equal or greater value.

What is not covered by this warranty?

1. Normal wear and tear of wearable parts (such as foam filters, HEPA filters, pads, etc.), which require regular maintenance and/or replacement to ensure the proper functioning of your unit, are not covered by this warranty. Replacement parts are available for purchase at sharkaccessories.com.
2. Any unit that has been tampered with or used for commercial purposes.
3. Damage caused by misuse (e.g., vacuuming up water or other liquids), abuse, negligent handling, failure to perform required maintenance (e.g., not cleaning the filters), or damage due to mishandling in transit.
4. Consequential and incidental damages.
5. Defects caused by repair persons not authorized by SharkNinja. These defects include damages caused in the process of shipping, altering, or repairing the SharkNinja product (or any of its parts) when the repair is performed by a repair person not authorized by SharkNinja.
6. Products purchased, used, or operated outside North America.

How to get service

If your appliance fails to operate properly while in use under normal household conditions within the warranty period, visit sharkclean.com/support for product care and maintenance self-help. Our Customer Service Specialists are also available at **1-800-798-7398** to assist with product support and warranty service options, including the possibility of upgrading to our VIP warranty service options for select product categories.

SharkNinja will cover the cost for the customer to send in the unit to us for repair or replacement. A fee of \$24.95 (subject to change) will be charged when SharkNinja ships the repaired or replacement unit.

How to initiate a warranty claim

You must call **1-800-798-7398** to initiate a warranty claim. You will need the receipt as proof of purchase. A Customer Service Specialist will provide you with return and packing instruction information.

How state law applies

This warranty gives you specific legal rights, and you also may have other rights that vary from state to state. Some states do not permit the exclusion or limitation of incidental or consequential damages, so the above may not apply to you.

To better assist you, we ask that you register the product and have it with you when you call.

BATTERY REMOVAL AND DISPOSAL

This product uses a rechargeable and reusable lithium-ion battery. When the battery no longer holds a charge, it should be removed from the vacuum and recycled. **DO NOT** incinerate or compost the battery.

When your lithium-ion battery needs to be replaced, dispose of it or recycle it in accordance with local ordinances or regulations. In some areas, it is illegal to place spent lithium-ion batteries in the trash or in a municipal solid waste stream. Return spent battery to an authorized recycling center or to retailer for recycling. Contact your local recycling center for information on where to drop off the spent battery.

For more information on battery removal for disposal, please visit sharkclean.com/batterysupport



The RBRC™ (Rechargeable Battery Recycling Corporation) seal on the lithium-ion battery indicates that the costs to recycle the battery at the end of its useful life have already been paid by SharkNinja. In some areas, it is illegal to place spent lithium-ion batteries in the trash or municipal solid waste stream and the RBRC program provides an environmentally conscious alternative.

RBRC, in cooperation with SharkNinja and other battery users, has established programs in the United States and Canada to facilitate the collection of spent lithium-ion batteries. Help protect our environment and conserve natural resources by returning the spent lithium-ion battery to an authorized SharkNinja service center or to your local retailer for recycling. You may also contact your local recycling center for information on where to drop off the spent battery, or call 1-800-798-7398.

RECORD THIS INFORMATION

Model Number: _____

Date of Purchase: _____
(Keep receipt)

Store of Purchase: _____

© 2024 SharkNinja Operating LLC.
Needham, MA 02494/Ville St. Laurent, Québec H4S 1A7
1-800-798-7398
sharkclean.com



SHARK is a registered trademark of SharkNinja Operating LLC.
PETEXTRACT and SHARK CYCLONE are trademarks of SharkNinja Operating LLC.
RBRC is a trademark of Rechargeable Battery Recycling Corporation.

This product may be covered by one or more U.S. patents. See sharkninja.com/patents for more information.

Illustrations may differ from actual product.