

---

# EX SERIES

## PORTABLE AIR CONDITIONER

Instructions for use. Keep these instructions

Visit [www.delonghi.com](http://www.delonghi.com) for a list of service

centers near you.

ELECTRIC CHARACTERISTICS

115 V~ 60 Hz

## CONDITIONNEUR D'AIR PORTATIF

Mode d'emploi . Conservez cette notice

Visitez [www.delonghi.com](http://www.delonghi.com) pour y voir une liste

des centres de réparation proches de chez vous.

CARACTÉRISTIQUES ÉLECTRIQUES

115 V~ 60 Hz



## SISTEMA DE AIRE ACONDICIONADO PORTÁTIL

Repase y guarde estas instrucciones.

Lea cuidadosamente este instructivo

antes de usar su aparato.

Visite [www.delonghi.com](http://www.delonghi.com) para ver la lista

de centros de servicios cercanos a usted.

CARACTERISTICAS ELECTRICAS:

115 V~ 60 Hz

---

**EN**

pag. 4

**FR**

page 14

**ES**

pág. 25

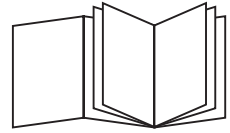

**A**

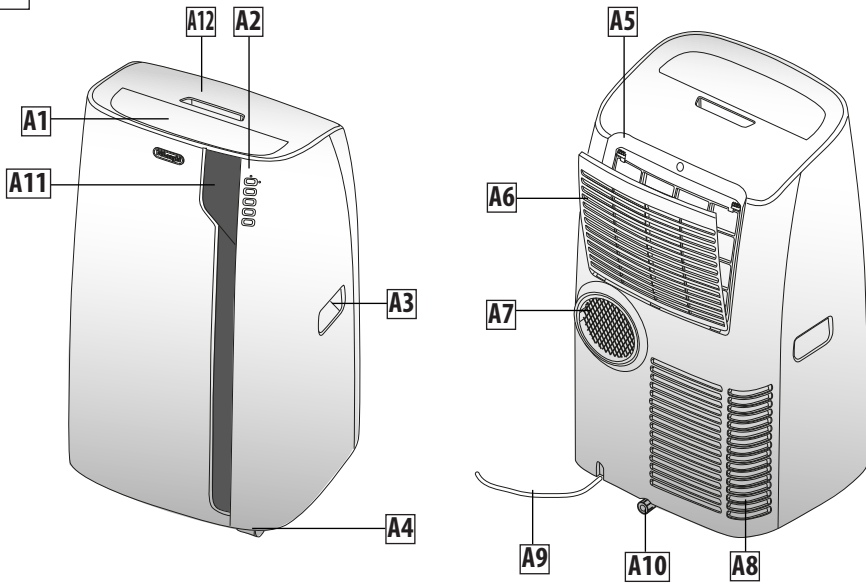

**B**

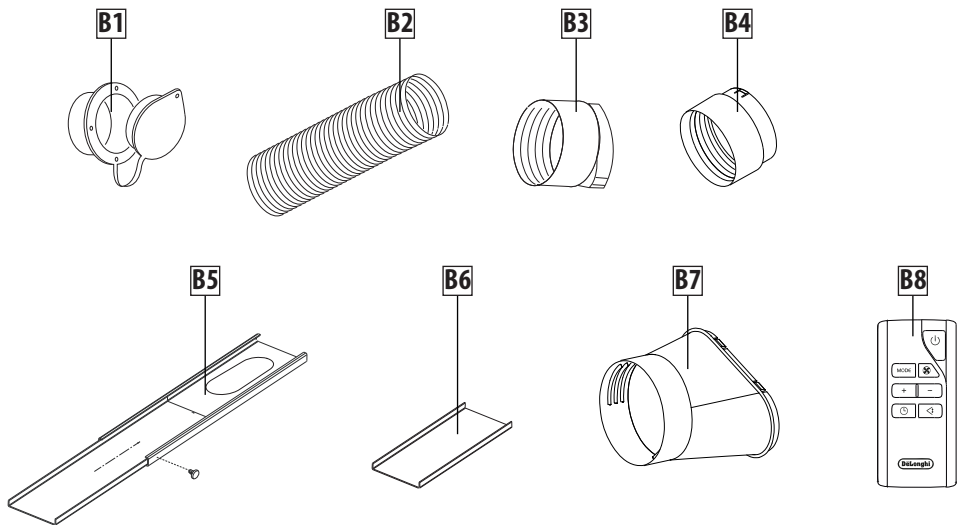

## Important safeguards

- Use this appliance only as described in this instruction manual.

As with any electrical appliance, the instructions aim to cover as many situations as possible. Caution and common sense should be used when operating and installing this air conditioner.

- This appliance has been manufactured to cool and dehumidify domestic environments and must not be used for other purposes.
- It is dangerous to alter or modify the unit's characteristics in any way.
- The appliance must be installed in accordance with the relevant national legislation.
- Should repairs be necessary, contact the nearest authorized Repair Service Center. Unauthorized servicing can be dangerous.
- The appliance is not intended for use by persons (including children) with reduced physical, sensory or mental capabilities, or lack of experience and knowledge, unless they have been given supervision or instruction concerning use of the appliance by a person responsible for their safety.

Children should be supervised to ensure that they do not play with the appliance.

- If the power cord is damaged, it must be replaced by the manufacturer or an authorized technical service center in order to avoid all risk.
- Always ensure the appliance is plugged into a grounded 3-prong outlet. If you have any doubts check with a qualified electrician.
- Do not use extension cords.
- Before cleaning or maintenance operations, always unplug the unit from the outlet.
- Do not pull on or place strain on the power cord when moving the appliance.
- The appliance should not be installed where the atmosphere may contain combustible gases, oil or sulphur, or near heat sources.
- Do not rest hot or heavy objects on the appliance.
- Clean the filters at least once a week.

- Avoid using heaters near the unit.
- The unit should be transported in a vertical position. If this is not possible secure the unit at an angle, do not lie it horizontally.
- Before transporting the unit, drain the unit. After transportation, wait at least 6 hours before switching the unit on.
- The packaging materials can be recycled. You are therefore recommended to place them in the special containers for differentiated waste collection.
- This appliance is fitted with a special safety device. When the compressor switches off, this device prevents it from switching on again for at least 3 minutes.
- **WARNING:** Changes or modifications not expressly approved by the party responsible for compliance could void the user's authority to operate the equipment.

### Specific warnings for appliances with R410A refrigerant gas

R410A is a refrigerant that complies with European ecological standards; nevertheless, it is recommended not to pierce the cooling circuit of the machine. At the end of its useful life, deliver the appliance to a special waste collection center for disposal.

This hermetically sealed system contains fluorinated greenhouse gases.

### ENVIRONMENTAL INFORMATION:

This unit contains fluorinated greenhouse gases covered by the Kyoto Protocol.

Maintenance and disposal must be carried out by qualified personnel only (R410A, GWP=2088).

**Save these instructions**  
This product is for household use only

## INTRODUCTION

Thank you for choosing a De'Longhi product. Please take a few moments to read the instructions to avoid risks or damage to the appliance.

## DESCRIPTION

**Description of the appliance (See page 3 - A)**

- A1 Air outlet grill
- A2 Control panel
- A3 Handles
- A4 Wheels
- A5 Filter
- A6 Air intake grill
- A7 Air exhaust hose housing
- A8 Air intake grill
- A9 Power supply cord
- A10 Drainage hose with 2 caps
- A11 Remote control signal receiver
- A12 Remote control compartment

**Description of accessories (See page 3 - B)**

- B1 Wall flange with cap
- B2 Air exhaust hose
- B3 Hose adaptor
- B4 Wall mounting accessory
- B5 Window bracket
- B6 Additional window bracket
- B7 Window outlet
- B8 Remote control
- B9 End of season dust cover (selct models only)
- B10 End of season accessories bag (selct models only)

## Electrical connection

Before plugging the appliance into the outlet, check that:

- The outlet's power supply corresponds to the value indicated on the rating label on the back of the appliance;
- The outlet and electrical circuit are adequate for the appliance;
- The outlet is a 3-hole grounded outlet (⚡). If this is not the case, you must choose another outlet. Failure to follow these important safety instructions absolves the manufacturer of all liability.

**If it becomes necessary, the power cord must be replaced by a qualified professional only.**

The instructions below will enable you to prepare your air conditioner for operation as efficiently as possible. Before use, make sure the air intake and outlet grills are unobstructed.

## USE

### NOTE:

**This appliance is provided with an auto evaporation feature for condensation removal during cooling and dehumidifying modes.**

## AIR CONDITIONING WITH INSTALLATION

**For optimal results set up your appliance in this way:**

- Screw the hose adaptor B3 and B4 to the hose's end B2 as shown in figure 1a.
- Fit the assembled air exhaust hose B2 in the housing at the back of the appliance. Insert it as shown in figure 1b.

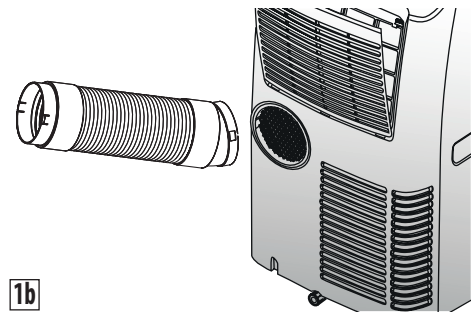
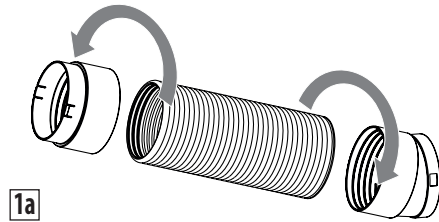

- Respect the distances given in figure 2.

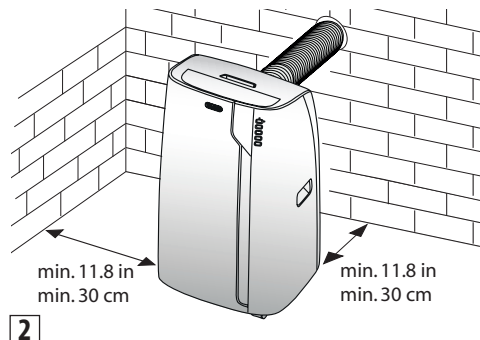

- Drill a hole  $\varnothing$  5,25 inches (134 mm) in an outside wall or through a window pane. Respect the dimensions and height of the hole given in figure 3 and 4.

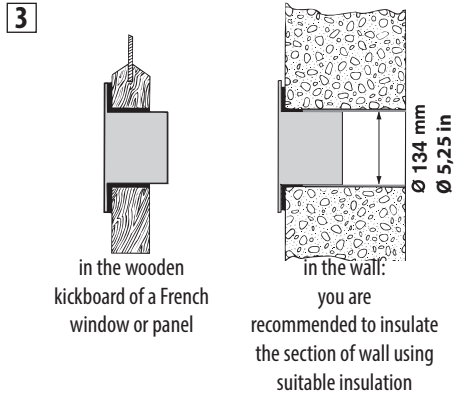

- Fit the wall flange **B1** into the hole.
- Fit the hose with the wall mounting accessory **B4** into the wall flange **B1** as shown in fig. 4.
- Fit the end of the hose **B2** to the wall flange **B1** as shown in fig. 4.
- When the hose **B2** is not connected, the drilled hole can be closed with the flange cap **B1**.

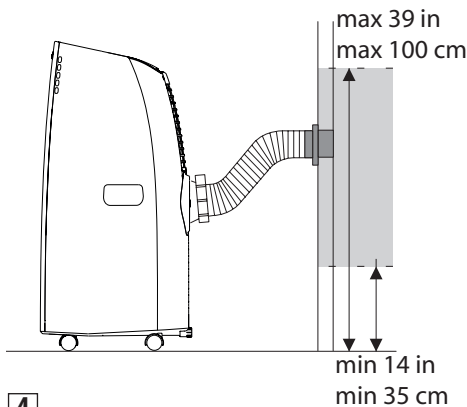

- When installing the air conditioner, you should leave a door slightly open 1/2" (1 cm) to guarantee correct ventilation and room pressure.
- Keep the air hoses as short and free of curves as possible to avoid constrictions.

**NOTE:**

- As special tools are required for installation, we suggest you have the appliance installed by a qualified professional.

**AIR CONDITIONING WITHOUT INSTALLATION**

You can also set up in a double-hung window:

- Place the window bracket in the window sill, extend the bracket fully within the window frame, fix the bracket by using the pin then lower the window onto the bracket. (Should the window bracket be too large for the window. The plastic can be cut with a saw by a qualified professional.)
- Screw the hose adaptor **B3** to the hose's end **B2**.
- Fit the air exhaust hose **B2** in the housing located on the rear side of the appliance. (fig. 1).
- Screw the window outlet **B7** to the other end of the exhaust hose.
- Insert the window outlet **B7** of the exhaust hose into the slot of the window bracket (fig. 5).



**Other set-up methods:**

- Thanks to the locking pins, it's possible to use the window bracket also for sliding windows. Position the hole of the bracket so to allow a correct installation of the exhaust hose (see figure 6).

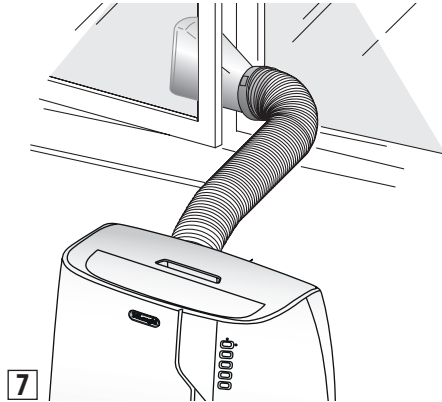
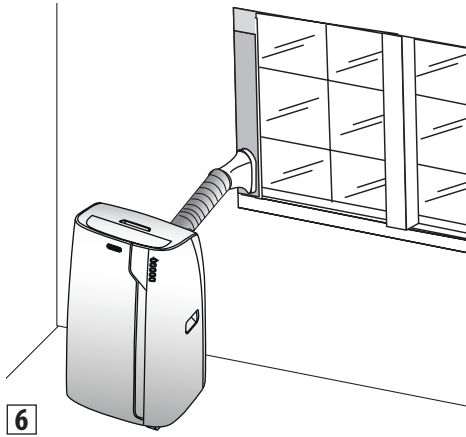

- If you have a casement window (figure 7) proceed as follows:
- Screw the hose adaptor **B3** to the hose's end **B2**.
- Fit the assembled air exhaust hose **B2** in the housing located on the rear side of the appliance (fig. 1) then, apply the window outlet **B7** to the air exhaust hose **B2** and place it outside the window to exhaust the hot air.

For help with installation, operation, and for all accessories and spare/replacement parts, please contact our toll free customer service call center at:  
**1-800-322-3848** [US only]  
**1-888-335-6644** [Canada only]  
 or log onto our website at [www.delonghi.com](http://www.delonghi.com)

## CONTROL PANEL

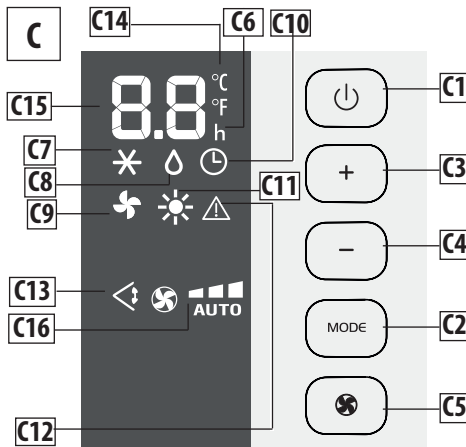

### DESCRIPTION OF THE CONTROL PANEL (C)

- C1** ON/STAND-BY (on/off) key
- C2** Function selection key **MODE** (air conditioner, dehumidifier, fan, heating)
- C3** Temperature increase key
- C4** Temperature decrease key
- C5** Fan speed selection key (MIN/MED/MAX/AUTO)
- C6** Hours indicator
- C7** Air conditioner symbol
- C8** Dehumidifier symbol
- C9** Fan symbol
- C10** Timer symbol
- C11** Heating symbol
- C12** Alarm symbol
- C13** Swing symbol
- C14** Selected temperature scale indicator
- C15** Set temperature values, programmed on/off time
- C16** Fan speed indicator

## OPERATING FROM THE CONTROL PANEL

### TURNING THE APPLIANCE ON/OFF

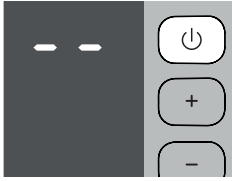

Before plugging the appliance check the cap on back of the unit are correctly inserted on drainage hose A10

Insert the plug in the socket. Two dashes appear on the display indicating that the appliance is in stand-by.

Touch the  (C1) key to turn on the appliance.

The flap A1 will open after few seconds.

When the appliance comes on, the last function set before it was shut off is activated.

**NOTE:** If start-up is not continued, after a few minutes the display light dims in order to reduce energy consumption.

To turn the appliance off, touch the  key and then pull the plug.

**NOTE:** Never turn off the air conditioner by simply pulling the plug. Touch the  key in order to put your air conditioner in stand-by and wait a few minutes before pulling the plug. In this manner, the appliance can perform the operating status checks.

### AIR CONDITIONING MODE

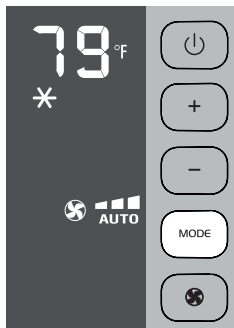

This is ideal for hot and humid weather when the room needs to be both cooled and dehumidified.

To correctly set this mode:

- Touch the **MODE** key until the air conditioning symbol appears. The display will show the desired temperature.
- To change the temperature to be reached, touch the + (C3) key or the - (C4) key.
- Select the desired fan speed by touching the  key.

The speeds available are:

 **Minimum speed:** when maximum silent operation is

desired.

 **Medium speed:** when the noise level needs to be low but with a good comfort level.

 **Maximum speed:** to reach the desired temperature as soon as possible.

 **AUTO** The appliance automatically chooses the best fan speed based on the temperature selected and the environmental conditions.

### DEHUMIDIFYING MODE

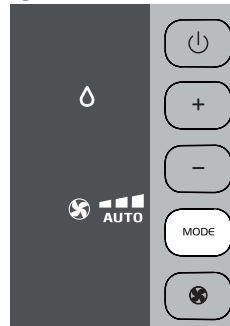

This is ideal for reducing humidity in the room (spring and autumn, damp rooms, rainy periods, etc. For this type of use, the appliance must be set up as for air conditioner mode. That is, the air exhaust hose (B2) must be fitted to the appliance to allow the humidity to be discharged outside.

To correctly set this mode:

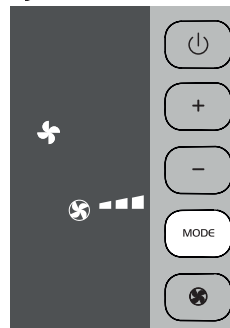

- Touch the **MODE** key until the dehumidifier symbol appears.
- The appliance automatically chooses the best fan speed.

### FAN MODE





When using this mode, the air exhaust hose (B2) does not need to be attached to the appliance.

To correctly set this mode:

- Touch the **MODE** key until the fan  symbol appears.
- Select the desired fan speed by touching the key .

The speeds available are:

 **Minimum speed:** when maximum silent operation is desired.

 **Medium speed:** when the noise level needs to be low but with a good fan level.

 **Maximum speed:** for maximum fan power.

## HEATING MODE

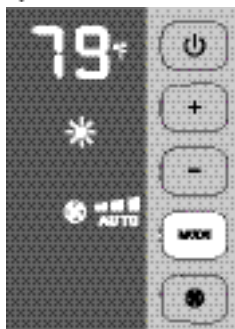

This is ideal in spring and autumn when outdoor temperatures are not particularly severe. For this mode, the appliance should be prepared in the same way as for air conditioning, with the air exhaust hose (B2) attached.

To set this mode:

- Touch repeatedly the MODE button until the heating symbol is displayed.
- Touch the increase (C3) or decrease (C4) keys to adjust the desired temperature.

### Notes:

- In this mode, the air flow is selected automatically by the appliance and cannot be set manually.
- When operating in very cold rooms, the appliance defreezes automatically, momentarily interrupting normal operation. In this case, "Lt" appears on the display. During this operation, it is normal for the noise made by the appliance to change.
- In this mode, you may have to wait a few minutes before the appliance starts giving out hot air.
- In this mode, the fan may operate for short periods, even though the set temperature has already been reached.
- It may happen that the display shows "HL" alarm. In this case, empty the internal safety tank following the instructions in the Section "End of Season operations". At the end, press again the  button to restore the heating function.

## SELECT THE TEMPERATURE SCALE

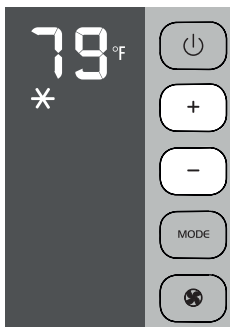

The temperature can be displayed in °C or °F.

To change the temperature unit of measure touch both keys "+" and "-" for about 10 sec.

## OPERATING FROM THE REMOTE CONTROL

### USING THE REMOTE CONTROL

- Point the remote control at the receiver (A11) on the air conditioner. The remote control must be no more than 16 ft (5 metres) away from the appliance (without obstacles between the remote control and the receiver).
- The remote control must be handled with care. Do not drop it or expose it to direct sunlight or sources of heat.

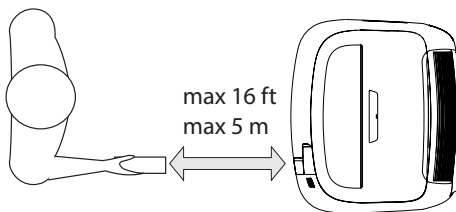

**NOTE:** The remote control can be safely stored in the appropriate compartment A12 (see figure).

## DESCRIPTION OF THE REMOTE CONTROL

D1) "ON/STAND-BY" button

D2.1) Temperature decrease / programmed operation button

D2.2) Temperature increase / programmed operation button

D3) "MODE" function button



D4) Fan speed selection button (  )

D5) SWING button (flap swing)

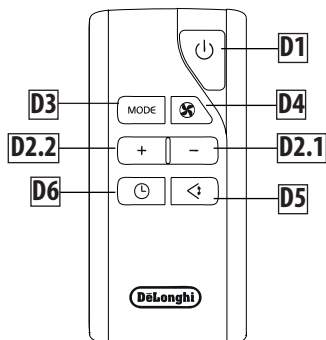
D6) TIMER button



## TURNING THE APPLIANCE ON

- Plug into the outlet.
- Press the  button (D1) (when turned on, the air conditioner starts operating in the same mode as when it was turned off).
- To switch the appliance off, press button (D1) , then remove the plug.

**NOTE:** Never switch the appliance off by removing the plug. Always switch it off by pushing on the  button and waiting few minutes before removing the plug. In this manner, the appliance can perform operating status checks.

## SELECTING THE OPERATING MODES

The commands available on the remote control correspond to those on the appliance control panel (C). Therefore, refer to the instructions in the previous chapters.

**NOTE:** The special functions D5-D6, are available from the remote control only.

## SWING BUTTON

The SWING button (D5) moves the grille flap, evenly distributing the air into the room.

When the SWING button is pressed, the flap will begin to move alternately forward and back.

If pressed again, the flap will be locked into its current position.

When the button is next pressed, the flap will start to move forward and back again.

**NOTE:** in order to avoid damaging the internal mechanisms, the flap must not be moved manually.

## SETTING THE TIMER

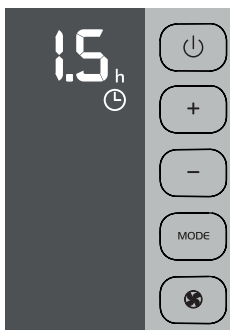

The timer allows for the delayed start up or shut down of the appliance. This function will prevent wasting electricity by optimising the operating periods.

## How to program delayed start up

- Plug in the appliance and set to standby.
- Press the timer key (D6): the timer symbol (C10) and hours (C6) light up.
- Use the + (D2.2) or - (D2.1) key to set the number of hours until the appliance should start up.

When the set time is elapsed, the appliance will start to operate in the same operating mode that was previously set.

Start up can be programmed at any time within the 24 hours that follow. A few seconds after the timer is set, the setting is acquired. The timer symbol stays lit and the display returns to standby.

To cancel the timer program, touch the timer key (D6) twice. The timer symbol (C10) will go off.

## How to program delayed shut down

- While the appliance is on in any operating mode, delayed shut down can be programmed.
- Press the timer key (D6): The timer symbol (C10) and hours (C6) light up.
- Use the + (D2.2) or - (D2.1) key to set the number of hours until the appliance will shut down.

A few seconds after the timer is set, the setting is acquired, the display shows the operating mode and the timer symbol stays lit.

Once the set time is elapsed, the air conditioner goes into standby. To cancel the timer program, touch the timer key (D6) twice. The timer symbol (C10) will go off.

## INSERTING OR REPLACING THE BATTERIES

- Remove the cover on the rear of the remote control;
- Replace the old batteries with two new R03 "AAA" 1.5V batteries, inserting them correctly (see the instructions inside the battery compartment);
- Replace the cover.

**If the remote control unit is replaced or discarded, the batteries must be removed and disposed of in accordance with current legislation as they are harmful to the environment. Do not mix old and new batteries.**

**Do not mix alkaline, standard (carbon-zinc) or rechargeable (nickel-cadmium) batteries. Do not dispose of batteries in fire. Batteries may explode or leak. If the remote control is not be used for a certain length of time, remove the batteries.**

### Note:

- This equipment has been tested and found to comply with the limits for a Class B digital device, pursuant to part 15 of the FCC Rules. These limits are designed to provide reasonable protection against harmful interference in a residential installation.
- This equipment generates, uses and can radiate radio frequency energy and, if not installed and used in accordance with the instructions, may cause harmful interference to radio communications. However, there is no guarantee

that interference will not occur in a particular installation. If this equipment does cause harmful interference to radio or television reception, which can be determined by turning the equipment off and on, the user is encouraged to try to correct the interference by one or more of the following measures:



- Reorient or relocate the receiving antenna.
- Increase the separation between the equipment and receiver.
- Connect the equipment into an outlet on a circuit different from that to which the receiver is connected.
- Consult the dealer or an experienced radio/TV technician for help.

Changes or modifications not expressly approved by the party responsible for compliance could void the user's authority to operate the equipment.

- This device complies with Part 15 of the FCC Rules. Operation is subject to the following two conditions: (1) this device may not cause harmful interference, and (2) this device must accept any interference received, including interference that may cause undesired operation.
- This Class B digital apparatus complies with Canadian ICES-003.

## SELF-DIAGNOSIS

The appliance has a self diagnosis system to identify a number of malfunctions. Error messages are displayed on the appliance display.

IF THE FOLLOWING APPEARS ON THE DISPLAY...	IF THE FOLLOWING APPEARS ON THE DISPLAY...	IF THE FOLLOWING APPEARS ON THE DISPLAY...
		
"Low Temperature"	"High Level"	"Probe Failure"
<p><b>... DO THE FOLLOWING</b></p> <p>The appliance has a defrosting device that prevents excessive ice build ups. The appliance automatically starts operating again once the defrosting process is complete.</p>	<p><b>... DO THE FOLLOWING</b></p> <p>Empty the inner water tray by following the instructions in the paragraph "END OF SEASON OPERATIONS".</p> <p>If the error occurs again, please contact our toll free customer service call center.</p>	<p><b>... DO THE FOLLOWING</b></p> <p>If this appears, please contact our toll free customer service call center.</p>

## TIPS FOR CORRECT USE

To ensure optimal results from your air conditioner, follow these recommendations:

- close the windows and doors in the room to be air conditioned. When installing the air conditioner semi-permanently, you should leave a door slightly open (as little as 0.39 inch. (1 cm)) to guarantee proper ventilation.

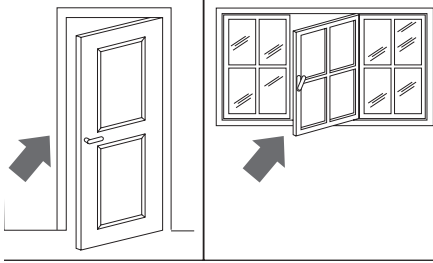

Close doors and windows

- Never use the appliance in very damp rooms (laundries for example).
- Protect the room from direct exposure to the sun by partially closing curtains and/or blinds to make the appliance much more economical to run

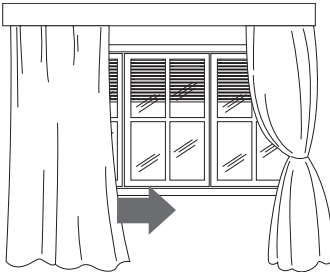

Close blinds or curtains

- Never use the appliance outdoors.
- Make sure there are no heat sources in the room;
- Make sure the air conditioner is standing on a level surface.

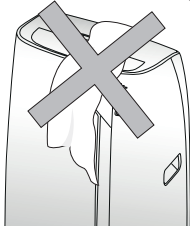

do not cover the appliance

- Never rest objects of any kind on the air conditioner;
- Never obstruct the air intake or outlet grills;

## CLEANING

Before cleaning or maintenance, turn the appliance off by touching the  button, then unplug from the outlet.

### CLEANING THE CABINET

You should clean the appliance with a slightly damp cloth then dry with a dry cloth. For safety reasons, never wash the air conditioner with water.

### Precautions

Never use petrol, alcohol or solvents to clean the appliance. Never spray insecticide liquids or similar.

### CLEANING THE AIR FILTER OR SILVER-ION AIR FILTER (if fitted)

To maintain the efficiency of the air conditioner, it is recommended to clean the dust filter after every week of use.

The filter is located near the intake grill. Remove the grill to access the filter. To clean the filter, it will need to be extracted as shown in fig. 8-9.

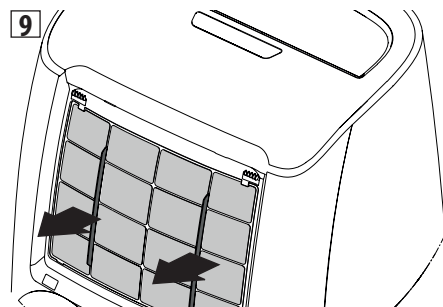
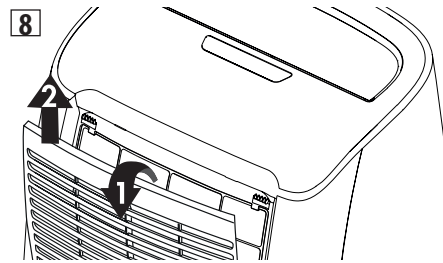

Use a vacuum cleaner to remove any dust deposited on the filter. If it is very dirty, submerge it into warm water and rinse it several times. The water temperature must be kept below 104° F. After washing the filter, allow it to dry. To replace, put the filter back in its housing. If present, the silver-ion air filter not only re-

tains powder particles, but also performs an efficient antibacterial action. In addition, it greatly reduces irritants such as pollen and spores. The filter is treated with small particles of silver (with dimensions equal to millionths of a millimeter) which are able to block the multiplication of bacteria and spores when in contact with them, and therefore encourage their destruction.

### CHECKS AT THE START OF THE SEASON

Make sure the power cord and socket are in perfect condition and make sure the earthing system is efficient. Comply strictly with the installation standards.

### END OF SEASON OPERATIONS

To completely drain the water from the internal circuit, remove the cap from the outside of the drainage hose, turning it counter clockwise. Then remove the internal cap (fig. 10). Drain the water completely into a basin. When it is completely drained, replace the caps, making sure they are completely closed. Clean the filter as indicated previously. The filter must be completely dry before reinserting it.

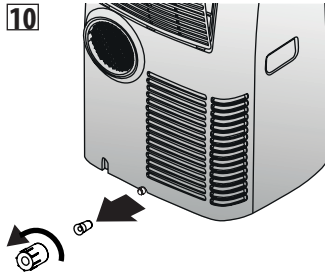

When the appliance is empty, replace the caps.  
Clean the filter and dry thoroughly before putting back.

In order to properly storage the appliance at the end of the season, we suggest you cover it with the supplied end of season dust cover **B9** and you put the accessories in the relevant end of season accessories bag **B10**.

### TECHNICAL SPECIFICATIONS

Power supply voltage	see rating label
Max. absorbed power during air conditioning	"
Refrigerant	"
Cooling capacity	"

### LIMIT CONDITIONS

Room temperature for  
air conditioning  $64 \div 95^{\circ}\text{F}$  ( $18^{\circ} \div 35^{\circ}\text{C}$ )

Room temperature for  
heating  $50 \div 77^{\circ}\text{F}$  ( $10 \div 25^{\circ}\text{C}$ )

**Transport, filling, cleaning, recovery and disposal of refrigerant should be performed by a technical service center appointed by the manufacturer only.**

**The appliance should be disposed of by a center appointed by the manufacturer only.**

### TO AVOID DAMAGE TO THE UNIT:

NEVER TRANSPORT OR TURN THE APPLIANCE UPSIDE DOWN OR ON ITS SIDE. IF THIS OCCURS, WAIT 6 HOURS BEFORE TURNING THE APPLIANCE ON, 24 HOURS IS RECOMMENDED. After the unit has been on its side, oil needs to return to the compressor to ensure proper function. Without allowing the unit this time (6-24 hours) the unit may function for only a short time, and then the compressor will break down from lack of oil.

### ELECTRICAL CONNECTION

This appliance is equipped with a 3 prong grounded plug. The plug must be connected into an outlet that is properly installed and grounded in the accordance with all local codes and ordinances. Do not modify the plug provided with the appliance. If it will not fit the outlet, have a proper outlet installed by a qualified electrician or relocate the unit to a proper outlet. If the household electrical supply does not meet the above specifications, or if you are not sure your home has an effective electrical ground, have a qualified electrician or your local electrical utility company check it and correct any problems.

### SAFETY PLUG

The appliance is fitted with a safety plug to protect the power cord. If power is cut off, unplug from the outlet and make sure the power cord is undamaged. If the cord is damaged, call the service center immediately. If power cuts off frequently and the power cord is undamaged, contact a qualified electrician.

### OPERATION OF THE SAFETY PLUG

If the safety device incorporated in the plug trips and cuts off the power supply, check that the power cord and plug are not damaged. If the power cord is undamaged, to restore operation press the "RESET" button. To verify correct operation of the plug, press the "TEST" button periodically and make sure the appliance disconnects. If this is not the case, contact the service center. To restore operation, press the "RESET" button.

## TROUBLESHOOTING

Check the following points before calling the authorized Technical Service Center in your area.

PROBLEMS	CAUSES	SOLUTIONS
The air conditioner does not turn on	It is not plugged in	plug it in
	there is no power	wait
	the internal protection device was triggered	call the help center
The air conditioner only works for a short period of time	the air exhaust hose is obstructed or bent	correctly position the air exhaust hose, limiting the length and curves as much as possible and avoiding any obstructions
	an obstruction is impeding air exhaust outside	identify and remove the obstacles that impede air exhaust outside
The air conditioner runs but does not cool the room	windows, doors, drapes open	close the windows, doors and drapes, keeping in mind the "recommendations for proper use"
	there is some heat source in the room (oven, hair dryer, etc.)	eliminate the heat source
	the air exhaust hose is disconnected from the appliance	attach the air exhaust hose to the housing on the back of the appliance (fig.1)
	dust filters clogged	clean or replace the filters as previously described
During operation there is an unpleasant odor in the room	dust filters clogged	clean or replace the filters as previously described
The air conditioner does not work for about 3 minutes from restart	to protect the compressor there is an internal device that delays startup for about 3 minutes from restart	wait; this time delay from restart is normal
The display shows the  symbol with one of the following messages: HL/PF	the appliance has a self-diagnosis system that identifies some operating errors	refer to the SELF-DIAGNOSIS chapter