

duraflame

MODEL: 22MM10691

INSERT MODEL: 22II026FGL

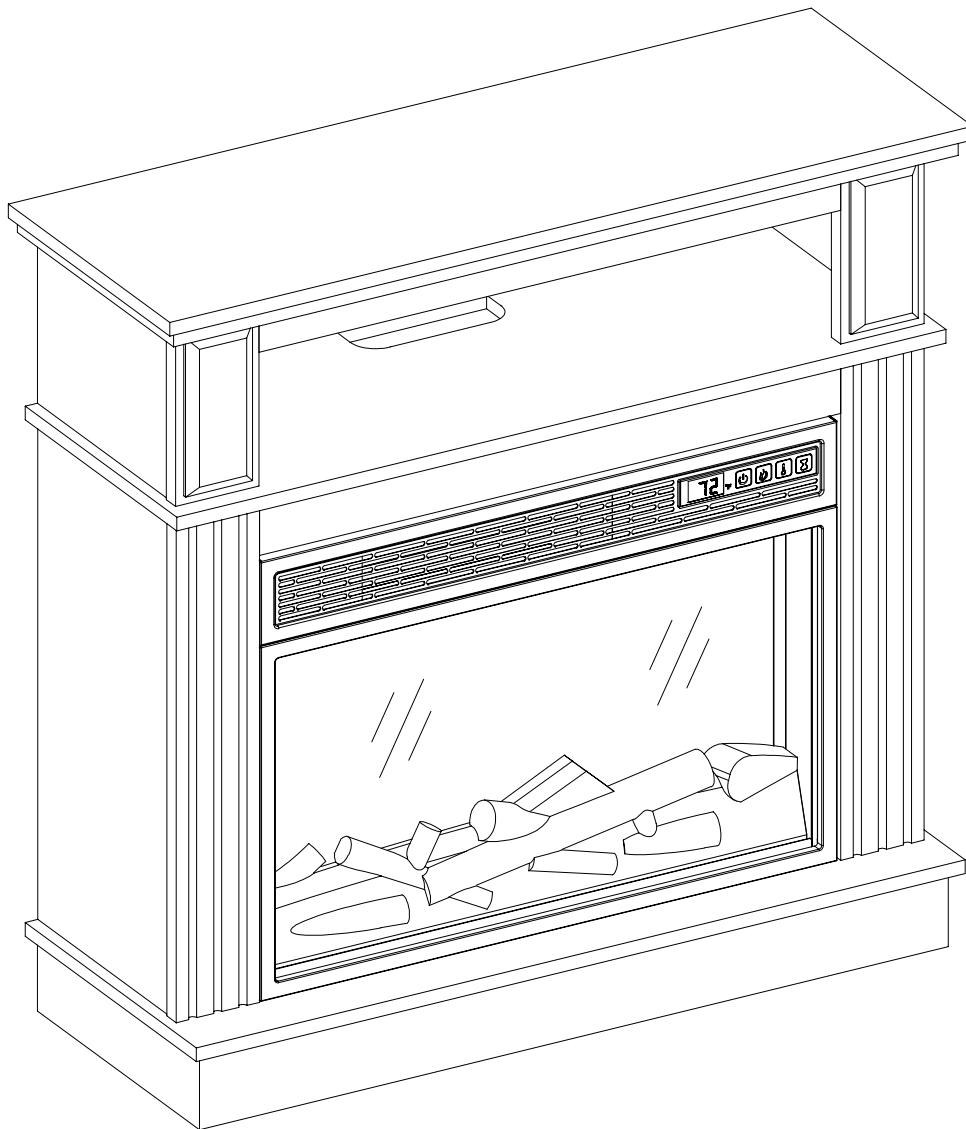

www.tsicustomerservice.com



1-888-674-7517

TWIN-STAR
INTERNATIONAL
HOME FURNISHINGS

Twin-Star International, Inc; Delray Beach, FL 33445
Made in China • Printed in China

THANK YOU!

Thank you for purchasing a Twin-Star International product, designed in the U.S.A. We hope it brings you many years of enjoyment. Please take a moment of your time to register your new purchase:

www.tsicustomerservice.com.

For new users simply select the category that applies to the product you've purchased and fill out the product registration form. Once the registration process is complete you will be able to:

- Register one or multiple products
- Order parts
- Download user manuals
- Request product information or assistance

When registering your product be sure to sign up for Twin-Star International updates, which will keep you informed of important service information, provide helpful tips about our products, and make it easier if you should ever have to contact our technical support group. Twin-Star International values your privacy and will never share your personal information with other organizations. The information you submit is used only for purposes of providing product related services to you.

If you are unable to register your product, please save your proof of purchase for part replacement purposes.

IMPORTANT:
Retain for future reference.
Read carefully.

MERCI!

Nous vous remercions d'avoir acheté un produit Twin-Star International, conçu aux États-Unis. Nous espérons qu'il saura vous procurer des années de satisfaction. Veuillez prendre un moment pour enregistrer votre nouvel achat :

www.tsicustomerservice.com.

Pour les nouveaux utilisateurs, sélectionnez simplement la catégorie qui s'applique au produit que vous avez acheté et remplissez le formulaire d'enregistrement du produit. Une fois le processus d'enregistrement complété, vous serez en mesure de:

- Enregistrer un ou plusieurs produits
- Commander des pièces
- Télécharger le manuel de l'utilisateur
- Demander de l'information ou de l'assistance sur le produit

Quand vos enregistrerez votre produit, assurez-vous de vous abonner aux mises à niveau de Twin-Star International, lesquelles visent à vous tenir au fait de toute information importante pour le service, à vous fournir des conseils utiles sur nos produits et à accélérer le processus si vous deviez contacter notre groupe de soutien technique. Twin-Star International se soucie de la protection de vos renseignements personnels et ne partagera jamais votre information personnelle avec d'autres organisations. L'information que vous soumettez est utilisée uniquement pour vous fournir des services en relation avec votre produit.

Si vous ne parvenez pas à enregistrer votre produit, s'il vous plaît gardez votre reçu comme preuve d'achat pour tout remplacement de pièces.

IMPORTANT:
Conserver pour référence future. Lisez correctement

GRACIAS!

Gracias por comprar un producto de Twin-Star International, diseñado en los E.U.A.

Esperamos que le brinde muchos años de disfrute. Por favor, tómese un momento de su tiempo para registrar su compra nueva:

www.tsicustomerservice.com.

Para los usuarios nuevos, simplemente seleccione la categoría que se aplica al producto que ha comprado y llene el formulario de registro del producto. Una vez finalizado el proceso de registro, usted podrá:

- Registrar uno o varios productos
- Realizar pedidos de piezas
- Descargar manuales de usuario
- Solicitar información o asistencia sobre el producto

Cuando registre su producto, asegúrese de suscribirse a las actualizaciones de Twin-Star International, las cuales le mantendrán informado sobre la información importante de servicio, le proporcionarán consejos útiles acerca de nuestros productos, y le facilitarán cuando tenga que contactar a nuestro grupo de soporte técnico. Twin-Star International valora su privacidad y nunca compartirá su información personal con otras organizaciones. La información que usted envíe sólo se utiliza para fines de proporcionarle servicios relacionados con los productos.

Si usted no puede registrar su producto, por favor guarde el comprobante de compra para el proposito de reponer piezas.

IMPORTANTE:
Conserver para futuras consultas. Lea cuidadosamente.

DEPENDABLE CUSTOMER SERVICE

Questions? Our message centers are available 7 days a week 24 hours a day at our toll-free help line. Our Customer Service department is available Monday – Friday 8:30 am – 5:30 pm EST. We can help you with assembly and if necessary, replace damaged/missing parts.



NO NEED TO RETURN
TO STORE!



Contact us at:
www.tsicustomerservice.com
for troubleshooting and
technical support.



For assistance with assembly or
installation, parts and customer
service, call:

1-888-674-7517

English, French, Spanish
8:30 AM – 5:30 PM Monday – Friday



Please have your store
receipt, instruction manual,
and part number ready when
you call.

UN SERVICE À LA CLIENTÈLE FIABLE

Questions? Nos centres d'appels sont disponibles 7 jours sur 7 et 24 heures sur 24 avec notre ligne d'assistance sans frais. Notre service à la clientèle est disponible du Lundi au Vendredi 8h30-17h30 HNE. Nous pouvons vous assister à l'assemblage et, si nécessaire, remplacer les pièces endommagées / manquantes.



UN SERVICE À LA
CLIENTÈLE FIABLE!



Contactez-nous au:
www.tsicustomerservice.com
pour le service de dépannage et
de soutien technique.



Pour assistance quant au montage
ou installation, pièces de rechange
ou service à la clientèle. Contactez:

1-888-674-7517

Anglais, Français, Espagnol
8h30-17h30 Lundi - Vendredi



Veuillez avoir en main, avant
de nous contacter, la facture de
votre marchand, votre manuel
d'instruction et le numéro de
pièce requise.

SERVICIO DE ATENCIÓN AL CLIENTE FIABLE

¿Tiene preguntas? Nuestro Centro de mensajes está disponible 7 días de la semana, 24 horas del día con nuestra línea de ayuda gratuita. Nuestro departamento de Servicio al Consumidor está disponible de Lunes a Viernes, de 8:30 am hasta las 5:30 pm EST. Le podemos ayudar con ensamblaje y si es necesario con el reemplazo de piezas dañadas o pérdidas.



NO ES NECESARIO
DEVOLVERLO A LA TIENDA!



Comuníquese con
nosotros en:
www.tsicustomerservice.com
para solución de problemas y
soporte técnico.



Para asistencia con la instalación
o ensamblaje, repuestos y
servicio al consumidor, llame al:

1-888-674-7517

Inglés, Francés, Español
8:30 AM – 5:30 PM Lunes – Viernes



Tenga a la mano su recibo
de la tienda, el manual de
instrucciones, y el número
de la pieza cuando realice la
llamada.

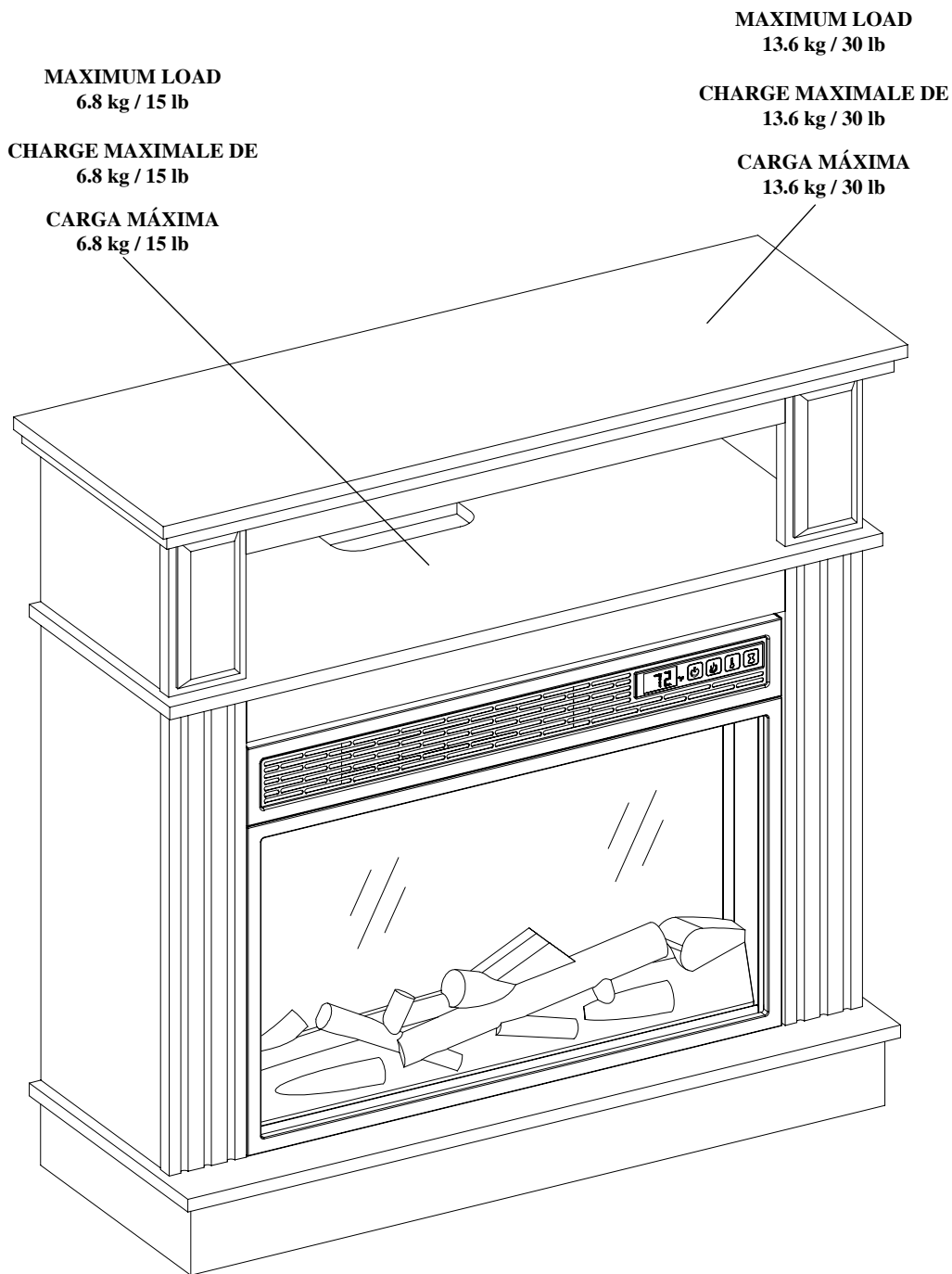

WARNING:

For use with most LCD/Plasma televisions weighing 13.6 kg / 30 lb or less. Use with televisions or loads heavier than the maximum weights specified may result in instability causing tip over resulting in death or serious injury.

ATTENTION:

Destiné à la plupart des téléviseurs à écran LCD/Plasma pesant 13.6 kg / 30 lb ou moins. Toute installation en vue de supporter des téléviseurs ou des charges d'un poids supérieur aux valeurs indiquées peut déboucher sur une instabilité provoquant un basculement pouvant entraîner la mort ou un accident grave.

PRECAUCIÓN:

Para usar con la mayoría de televisiones de LCD / Plasma, con peso de 13.6 kg / 30 lb o inferior. Utilizar con televisores o cargas más pesadas que los pesos máximos especificados puede dar lugar a inestabilidad que produzca un vuelco que tenga como resultado muerte o lesiones graves.

SAFETY INFORMATION



Please read and understand this entire manual before attempting to assemble, operate or install the product.



WARNING

- Some steps are more easily handled with two adults.

CAUTION

- Before assembly and/or installation, carefully unwrap all parts.
- Locate and set aside the hardware kit before discarding packaging.
- Use care when assembling your new product. Take your time and follow the assembly instructions closely.

INFORMATION DE SÉCURITÉ



Assurez-vous de lire et de comprendre l'intégralité du présent manuel avant de tenter d'assembler, d'utiliser ou d'installer le produit.



AVERTISSEMENT

- Certaines étapes sont plus faciles à effectuer avec l'aide

MISE EN GARDE

- Avant l'assemblage et/ou l'installation, vous devez déballer minutieusement toutes les pièces.
- Localisez et mettez de côté le jeu de quincaillerie avant de jeter l'emballage.
- Soyez vigilant lorsque vous assemblez le nouveau produit. Prenez votre temps et suivez attentivement ces instructions.

INFORMACIÓN DE SEGURIDAD



Lea y comprenda completamente este manual antes de intentar ensamblar, usar o instalar el producto.



ADVERTENCIA

- Algunos de los pasos se pueden realizar con mayor facilidad entre dos adultos.

PRECAUCIÓN

- Antes del ensamblaje y/o instalación, desenvuelva cuidadosamente todas las piezas.
- Localice y separe el equipo de accesorios antes de desechar el embalaje.
- Tenga cuidado al ensamblar el nuevo producto. Tómese su tiempo y siga detenidamente las instrucciones de ensamblaje.

TOOLS REQUIRED OUTILS NÉCESSAIRES HERRAMIENTAS NECESARIAS

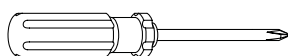

(NOT INCLUDED)
(PAS INCLUS)
(NO INCLUIDAS)

HARDWARE/QUINCAILLERIE/FERRETERÍA

[x1]

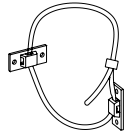

AA

PH-BKTWHT003

[x1]



ZZ

Touch-Up pen
(NOT TO SCALE)

REPLACEMENT PARTS 22MM10691 PIECES DE REMPLACEMENT 22MM10691 PARTES DE REPUESTO 22MM10691

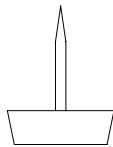

BB

PH-GLDBRW001

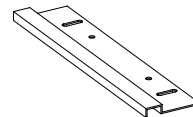

CC

PH-BKTZNC001

1

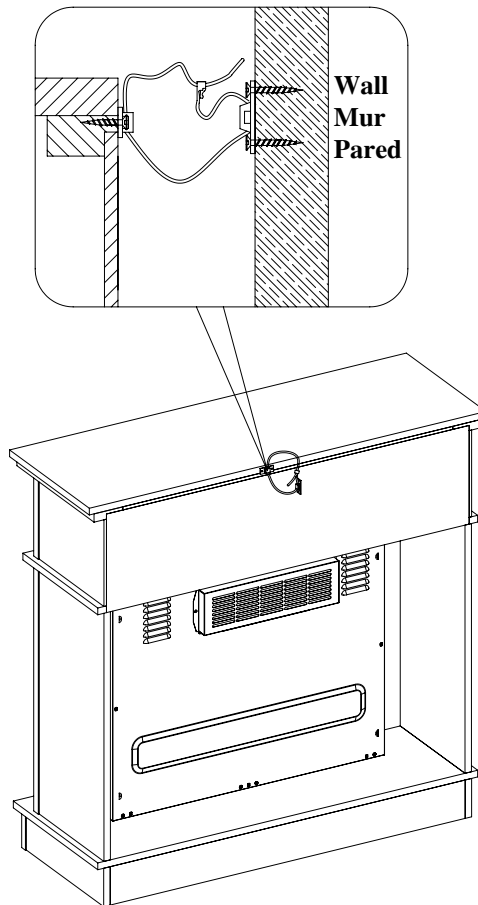

WARNING: You must install the tipping restraint hardware to help prevent any accidents or damage to the unit.

We strongly recommend mounting this hardware to a wall stud and your unit.

AVERTISSEMENT: Il est nécessaire d'installer les pièces d'arrimage anti basculement pour prévenir les accidents ou les dommages à l'unité.

Il est fortement recommandé de fixer ces pièces sur un poteau mural et sur le meuble.

ADVERTENCIA: Debe instalar el Herraje contra Caídas para evitar accidentes o que se dañe la unidad.

Recomendamos montar estos herrajes a un taco de pared y a la Unidad.

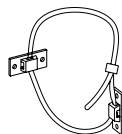

[x1]

GETTING STARTED

1. Remove the product identification sticker from the front of the insert.

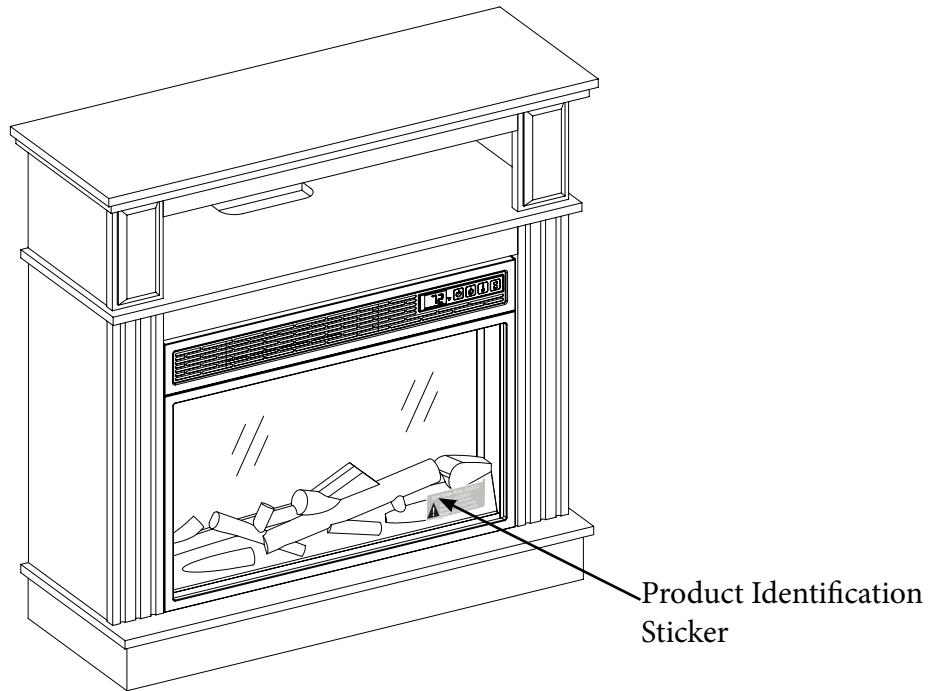

2. Attach the Product Identification Sticker to the Manual below for future reference. This information is used for product registration and also is necessary for customer service.

Attach Product Identification Sticker Here



3. Go to www.tsicustomerservice.com for product warranty registration. If you are unable to complete registration save your proof of purchase for warranty purposes.

PRODUCT SPECIFICATIONS

VOLTAGE	120VAC, 60 Hz
AMPS	12.5 Amps
WATTS	1500 Watts

IMPORTANT INSTRUCTIONS

When using electrical appliances, basic precautions should always be followed to reduce the risk of fire, electrical shock, and injury to persons including the following:

1. Read all instructions before using this appliance.
2. **DANGER** – High temperatures may be generated under certain abnormal conditions. Do not partially or fully cover or obstruct the front of this heater. **WARNING:** In order to avoid overheating, do not cover the heater.
3. **CAUTION:** Never leave the heater operating unattended. Extreme caution is necessary if unsupervised children or invalids are nearby.
4. The appliance is not to be used by children or persons with reduced physical, sensory or mental capabilities, or lack of experience and knowledge, unless they have been given supervision or instruction.
5. Always unplug this appliance when not in use.
6. Do not operate any heater with a damaged cord or plug or after the appliance malfunctions, or if it has been dropped or damaged in any manner.
7. If the supply cord is damaged, it must be replaced by the manufacturer, its service agent or similarly qualified persons in order to avoid a hazard.
8. Do not use outdoors.
9. This heater is not intended for use in bathrooms, laundry areas and similar indoor locations. Never locate this appliance where it may fall into a bathtub or other water container.
10. Do not run cord under carpeting. Do not cover cord with throw rugs, runners or the like. Arrange cord away from traffic areas and where it will not be tripped over.
11. To disconnect this appliance, turn controls to the off position, then remove plug from outlet.
12. Connect to properly grounded outlets only. This heater is for use on 120 volts. The cord has a plug as shown at A in Fig.1.

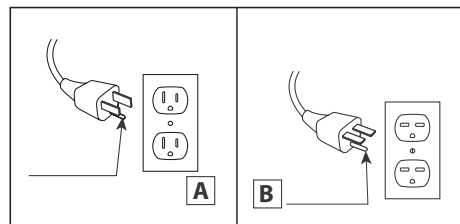
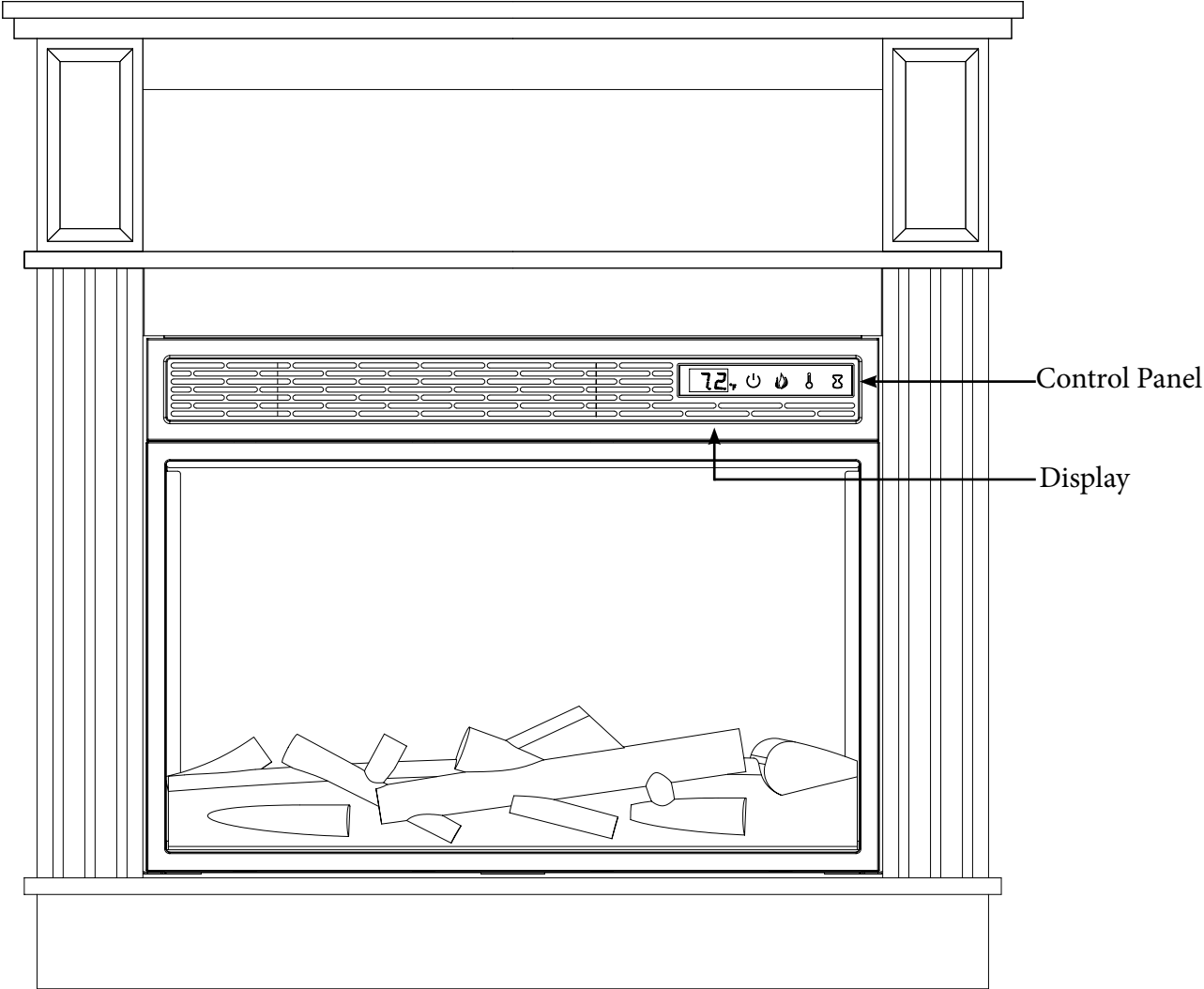

Fig.1

13. This appliance, when installed, must be electrically grounded in accordance with local codes or, in the absence of local codes, with the current CSA C22.1 Canadian Electrical Code or for U.S.A. installations, follow local codes and the National Electrical Code, ANSI/NFPA NO.70.
14. Do not insert or allow foreign objects to enter any ventilation or exhaust opening as this may cause an electric shock or fire, or damage the appliance.
15. To prevent a possible fire, do not block air intakes or exhaust in any manner. Do not use on soft surfaces, like a bed, where opening may become blocked.
16. This appliance has hot and arcing or sparking parts inside. Do not use it in areas where gasoline, paint or flammable liquids are used or stored. This fireplace should not be used as a drying rack for clothing. Christmas stockings or decorations should not be hung in the area of it.
17. Use this appliance only as described in the manual. Any other use not recommended by the manufacturer may cause fire, electric shock or injury to persons.
18. This heater may include a visual alarm to warn that parts of the heater are getting excessively hot. If the alarm flashes immediately turn the heater off and inspect for any objects on or adjacent to the heater that may cause high temperatures.
DO NOT OPERATE THE HEATER WITH THE ALARM FLASHING!
19. Avoid the use of an extension cord because of the risk of overheating the cord and the risk of fire. Extension cords are for temporary use only. If an extension cord must be used, it must be UL/CSA certified, rated at 15A (1875W), 125V maximum with 14AWG minimum and constructed of two current carrying conductors with ground. A heavy duty extension cord with the shortest length possible for the connection is recommended and must not be longer than 50 ft. (15.2m). Do not coil or cover the extension cord.

SAVE THESE INSTRUCTIONS





OPERATION INSTRUCTIONS



The heater can be operated by either the remote control or the control panel.



OPERATION INSTRUCTIONS

FUNCTION	ICON	DESCRIPTION
POWER		<p>The power button supplies power to all of the functions of the fireplace. The power button will put the insert in a standby mode. This will turn off all functions at once but will hold the settings in the memory. By pressing the Power button again the unit will turn on at the same settings.</p> <p>With the power on press and hold the Power button on the control panel for 10 seconds to disable or re-enable the heater function. Once disabled or re-enabled the embered lights will flash multiple times.</p>
FLAME		<p>There are 5 brightness levels that can be selected .</p> <p>Settings F5- F1 decrease in brightness.</p>
HEATER		<p>The fireplace contains two infrared quartz heating elements.</p> <p>The thermostat setting range is 62°F - 82°F (17°C - 27°C) or continuously ON. To set flame effect so that it works without heat, press the heater button until the display shows “00”.</p> <p>The thermostat is adjustable by 2°F or 1°C increments.</p> <p>To change between °F and °C press and hold the HEATER button on the control panel for 3 seconds.</p>
TIMER		<p>Pressing the timer button will cycle through the timer settings; 30 minutes, 1 Hour, 2H, 3H, 4H, 5H, 6H, 7H, 8H, 9H and off (00).</p>
COOL DOWN CYCLE		<p>After the fireplace has ran the fan will continue to run for a COOL DOWN CYCLE period of time to cool down the internal parts.</p>

TROUBLESHOOTING

Problem	Root Cause	Corrective Action
Display shows “ E 1 ”	The thermostat sensor is broken or disconnected.	Unplug the fireplace, remove the back panel of the fireplace and check that the thermostat is plugged into the main circuit board. If this does not solve the problem contact customer service for a replacement thermostat sensor.
Display shows “ E 2 ”	The thermostat sensor is broken.	Contact customer service for a replacement thermostat sensor.
Display shows “ E 3 ”	Manual Reset overheat protection has triggered.	Inspect the heater and check that the air inlets and outlets are not blocked as this may cause overheating. Unplug the heater for 30 minutes and allow it to cool down. Replug and operate, monitor the heater for signs of overheating, if the problem persist discontinue use of the heater and contact customer service.
Display shows “ E 4 ”	Normal operation.	Check your heater cord and plug connections. Faulty wall outlet connections or loose plugs can cause the outlet or plug to overheat. Be sure the plug fits tight in the outlet. Heaters draw more current than small appliances, overheating of the outlet may occur even if it has not occurred with the use of other appliances. During use check frequently to determine if your plug outlet or faceplate is HOT! If so, discontinue use of the heater and have a qualified electrician check and/or replace the faulty outlet(s).
Heater does not blow warm air.	Cool down cycle.	Normal operation, will continue to run for several minutes before shutting down. Times will vary based on temperatures. During this time cool air will blow.
No power, logs do not glow.	No power to the unit	Check that unit is plugged into a standard 120V outlet. Press power button several times, make sure power is set at “ON” position.
Logs glow, but no flame effect.	Flame effect turned off	Press flame button several times.
Heater does not blow warm air.	Thermostat setting is preventing heater from turning on.	Adjust the temperature settings to ensure that the thermostat is set higher than the current room temperature.
Flame effect works but heater function does not and the emberbed flashes when the heater button is pressed.	The heater is disabled.	With the power on press and hold the POWER button on the control panel for 10 seconds. Once re-enabled the emberbed lights will flash multiple times.
Remote Control is not working.	No batteries	Change the remote batteries.
	Poor Signal	Operate remote transmitter at a slow measured pace. Press the remote control buttons with an even motion and gentle pressure. Repeatedly pressing buttons in rapid succession may cause the transmitter to malfunction.
	Distance	Operate the remote at a distance less than 20 feet from the front of the appliance; point the remote at the control panel.

EXPLODED VIEW

Part	Part Name	Part Number
1	Front Glass with Frame	Y17-S215-P27
2	Emberbed with Logset	Y17-S215-P02
3	Emberbed Circuit Board	Y17-S215-P44E
4	Flame Circuit Board	Y17-S215-P40
5	Flame Generator Drive Motor	P10-6-Q
6	Control Panel Circuit Board	Y17-S215-P32
7	Main Circuit Board	Y17-S215-P15
8	Thermostat Sensor	INS-NTC
9	Heater/Blower Assembly	Y17-S215-P01
10	Remote Control	P136

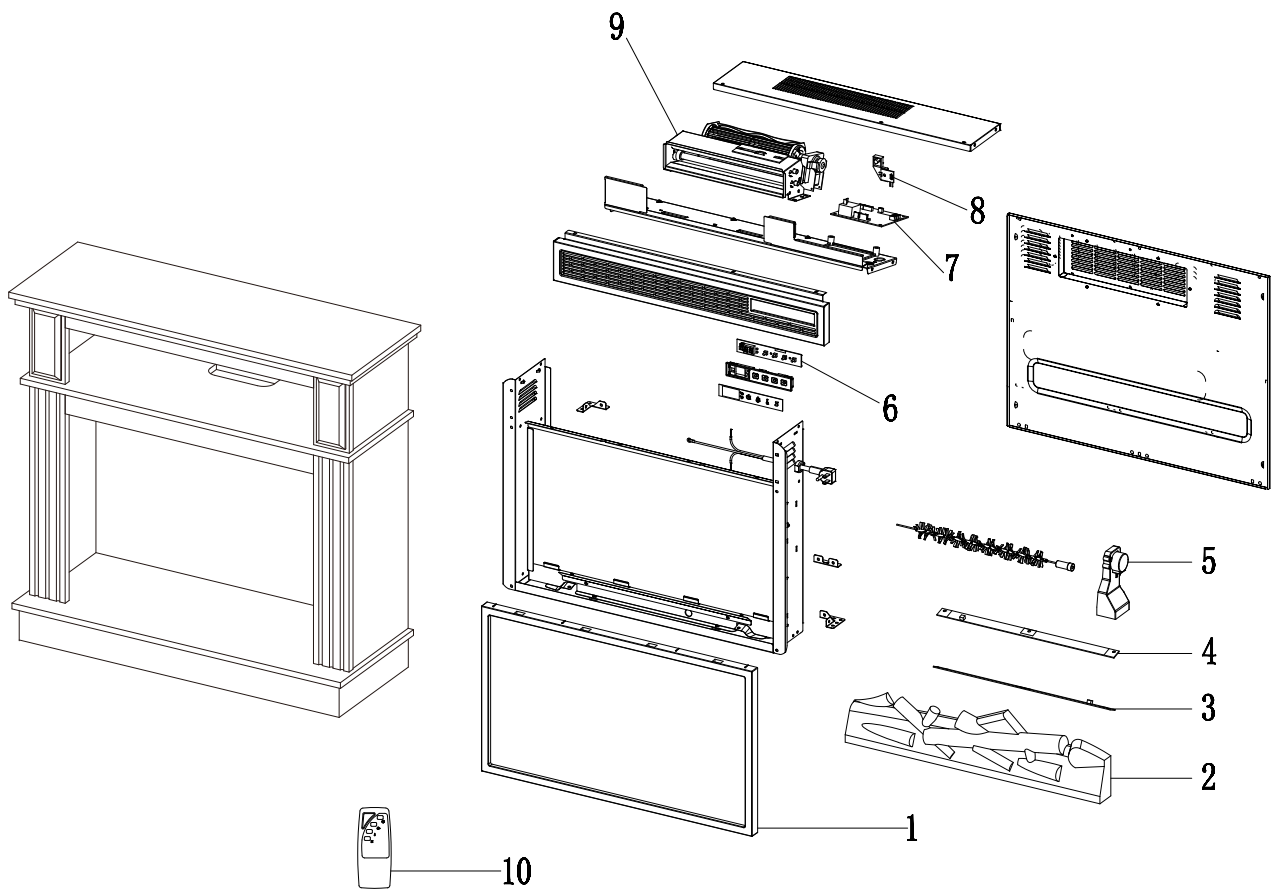

CARE AND MAINTENANCE

- The motors used on the fan and the flame generator assembly are pre-lubricated for extended bearing life and require no further lubrication. However, we recommend periodic cleaning/vacuuming of the fan/heater.
- Clean the trim using a soft cloth, slightly dampened with citrus oil based product and buff with a clean soft cloth. DO NOT use brass polish or household cleaners as these products will damage the metal trim. Citrus oil based products can be obtained at supermarkets or hardware stores.
- Make sure the unit is turned OFF and unplugged before cleaning the heater or fireplace.

FCC/IC INFORMATION

Warning: Changes or modifications to this unit not expressly approved by the party responsible for compliance could void user's authority to operate the equipment.

NOTE: This equipment has been tested and found to comply with the limits for Class B digital device, pursuant to part 15 of the FCC Rules. These limits are designed to provide reasonable protection against harmful interference in a residential installation. This equipment generates, uses, and can radiate radio frequency energy and, if not installed and used in accordance with the instructions, may cause harmful interference to radio communications. However, there is no guarantee that interference will not occur in a particular installation. If this equipment does cause harmful interference to radio or television reception, which can be determined by turning the equipment off and on, the user is encouraged to try to correct the interference by one or more of the following measures:

- Reorient or relocate the receiving antenna.
- Increase the separation between the equipment and the receiver.
- Connect the equipment into an outlet on a circuit different from that to which the receiver is connected.
- Consult the dealer or an experienced radio/TV technician for help.

This device complies with Part 15 of the FCC Rules. Operation is subject to the following two conditions:

- (1) This device may not cause harmful interference, and
- (2) this device must accept any interference received, including interference that may cause undesired operation.

This Class B digital apparatus complies with Canadian ICES-003.

BATTERY REPLACEMENT

- For best results, use 2pcs AAA alkaline batteries.
- Install only new batteries of the same type in your product.
- Failure to insert batteries in the correct polarity, as indicated in the battery compartment, may shorten the life of the batteries or cause batteries to leak.
- Do not mix old and new batteries.
- Do not mix Alkaline, Standard (Carbon-Zinc) or Rechargeable (Nickel Cadmium) or (Nickel Metal Hydride) batteries.
- Danger of explosion if battery is incorrectly replaced.
- Do not ingest batteries.

Batteries should be recycled or disposed of as per state and local guidelines.

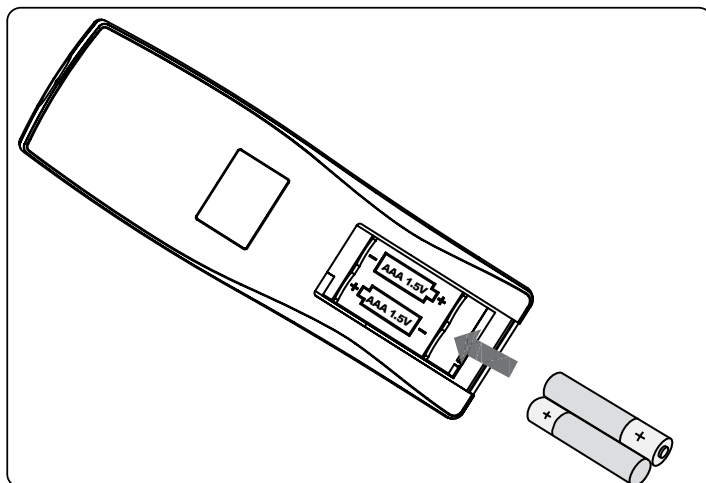

Nota:

Eliminación de batería
Siempre deseché las baterías
en un punto adecuado de reciclaje.

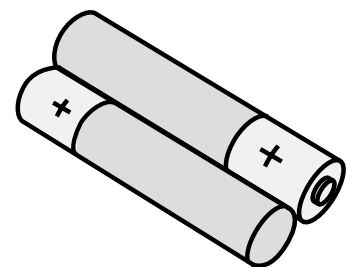

1-YEAR LIMITED WARRANTY

The manufacturer warrants that your new Electric Fireplace is free from manufacturing and material defects for a period of one year from date of purchase, subject to the following conditions and limitations.

1. Install and operate this appliance in accordance with the installation and operating instructions furnished with the product at all times. Any unauthorized repair, alteration, willful abuse, accident, or misuse of the product shall nullify this warranty.
2. This warranty is non-transferable, and is made to the original owner, provided that the purchase was made through an authorized supplier of the product.
3. The warranty is limited to the repair or replacement of part(s) found to be defective in material or workmanship, provided that such part(s) have been subjected to normal conditions of use and service, after said defect is confirmed by the manufacturer's inspection.
4. The manufacturer may, at its discretion, fully discharge all obligations with respect to this warranty by refunding the wholesale price of the defective part(s).
5. Any installation, labor, construction, transportation, or other related costs/expenses arising from defective part(s), repair, replacement, or otherwise of same, will not be covered by this warranty, nor shall the manufacturer assume responsibility for same.
6. The owner/user assumes all other risks, if any, including the risk of any direct, indirect or consequential loss or damage arising out of the use, or inability to use the product, except as provided by law.
7. All other warranties – expressed or implied – with respect to the product, its components and accessories, or any obligations/liabilities on the part of the manufacturer are hereby expressly excluded.
8. The manufacturer neither assumes, nor authorizes any third party to assume on its behalf, any other liabilities with respect to the sale of the product.
9. The warranties as outlined within this document do not apply to non accessories used in conjunction with the installation of this product.
10. This warranty gives you specific legal rights, and you may also have other rights which vary from state to state.

This warranty is void if:

- a. The fireplace is subjected to prolonged periods of dampness or condensation.
- b. Any unauthorized alteration, willful abuse, accident, or misuse of the product.
- c. You do not have the original receipt of purchase.

CUSTOMER SERVICE

www.tsicustomerservice.com

For Customer Service Call 1-888-674-7517

Questions? Our message centers are available 7 days a week 24 hours a day at our toll-free help line. Our Consumer Service department is available Monday – Friday 8:30 am – 5:30 pm EST. We can help you with assembly and if necessary, replace damaged/missing parts.

IMPORTANT:

Before contacting Customer Service please have this information available:

- Serial Number
- Model Number
- Sales Receipt or Proof of Purchase

duraflame[®]

www.tsicustomerservice.com