

# duraf<sup>l</sup>ame

**MODELS :**  
**18II210GRA, 23II210GRA**



**TWIN-STAR**<sup>®</sup>  
INTERNATIONAL  
HOME FURNISHINGS

**[www.tsicustomerservice.com](http://www.tsicustomerservice.com)**

Distributed by • Distribuido por • Distribué par • Twin-Star International, Inc; Delray Beach, FL 33445

Made in China • Printed in China • Fabricado en China • Impreso en China • Fabriqué en China • Imprimé en Chine

**Warning:** This is an unvented, electric appliance.  
**DO NOT** attempt to burn wood or manufactured  
firelogs in or on this appliance or grate.

**Advertencia:** Este es un aparato eléctrico sin  
ventilación. **NO** intente quemar leños fabricados ni  
madera dentro o sobre este aparato o su parrilla.

**Avertissement :** Il s'agit d'un appareil électrique  
non ventilé. **NE PAS** tenter de faire brûler du bois  
ou des bûches fabriquées dans l'appareil ou sur  
la grille.

# GETTING STARTED

---

1. Remove the product identification sticker from the front of the insert.

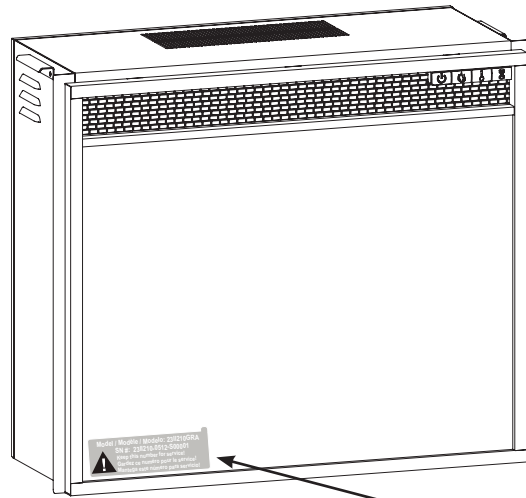

Product Identification Sticker

2. Attach the Product Identification Sticker to the Manual below for future reference. This information is used for product registration and also is necessary for customer service.

Attach Product Identification Sticker Here



3. Go to [www.tsicustomerservice.com](http://www.tsicustomerservice.com) for product warranty registration. If you are unable to complete registration save your proof of purchase for warranty purposes.

## PRODUCT SPECIFICATIONS

---

VOLTAGE	120VAC, 60 Hz
AMPS	12.5Amps
WATTS	1500 Watts

# IMPORTANT INSTRUCTIONS

When using electrical appliances, basic precautions should always be followed to reduce the risk of fire, electrical shock, and injury to persons including the following:

1. Read all instructions before using this appliance.
2. This appliance is hot when in use. To avoid burns, do not let bare skin touch hot surfaces. If provided, use handles when moving this appliance. Keep combustible materials, such as furniture, pillows, bedding, papers, clothes and curtains at least 3 feet (0.9 m) from the front of this appliance and keep away from the sides and the rear. **WARNING:** In order to avoid overheating, do not cover the heater.
3. **CAUTION:** Never leave the heater operating unattended. Extreme caution is necessary if unsupervised children or invalids are nearby.
4. The appliance is not to be used by children or persons with reduced physical, sensory or mental capabilities, or lack of experience and knowledge, unless they have been given supervision or instruction.
5. Always unplug this appliance when not in use.
6. Do not operate any heater with a damaged cord or plug or after the appliance malfunctions, or if it has been dropped or damaged in any manner.
7. If the supply cord is damaged, it must be replaced by the manufacturer, its service agent or similarly qualified persons in order to avoid a hazard.
8. Do not use outdoors.
9. This heater is not intended for use in bathrooms, laundry areas and similar indoor locations. Never locate this appliance where it may fall into a bathtub or other water container.
10. Do not run cord under carpeting. Do not cover cord with throw rugs, runners or the like. Arrange cord away from traffic areas and where it will not be tripped over.
11. To disconnect this appliance, turn controls to the off position, then remove plug from outlet.
12. Connect to properly grounded outlets only. This heater is for use on 120 volts. The cord has a plug as shown at A in Fig.1 Do not use a 2 prong adapters. Never use with an extension cord or relocatable power tap (power strip).

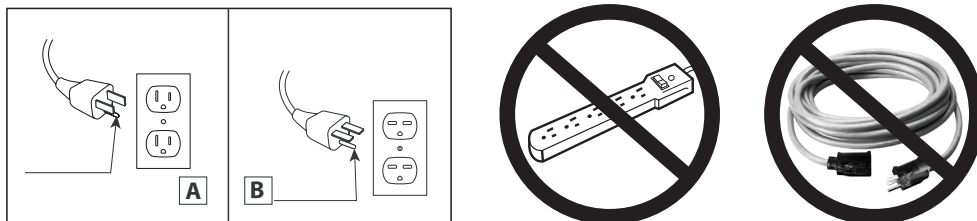

13. This appliance, when installed, must be electrically grounded in accordance with local codes or, in the absence of local codes, with the current CSA C22.1 Canadian Electrical Code or for U.S.A. installations, follow local codes and the National Electrical Code, ANSI/NFPA NO.70.
14. Do not insert or allow foreign objects to enter any ventilation or exhaust opening as this may cause an electric shock or fire, or damage the appliance.
15. To prevent a possible fire, do not block air intakes or exhaust in any manner. Do not use on soft surfaces, like a bed, where opening may become blocked.
16. This appliance has hot and arcing or sparking parts inside. Do not use it in areas where gasoline, paint or flammable liquids are used or stored. This fireplace should not be used as a drying rack for clothing. Christmas stockings or decorations should not be hung in the area of it.
17. Use this appliance only as described in the manual. Any other use not recommended by the manufacturer may cause fire, electric shock or injury to persons.

## SAVE THESE INSTRUCTIONS

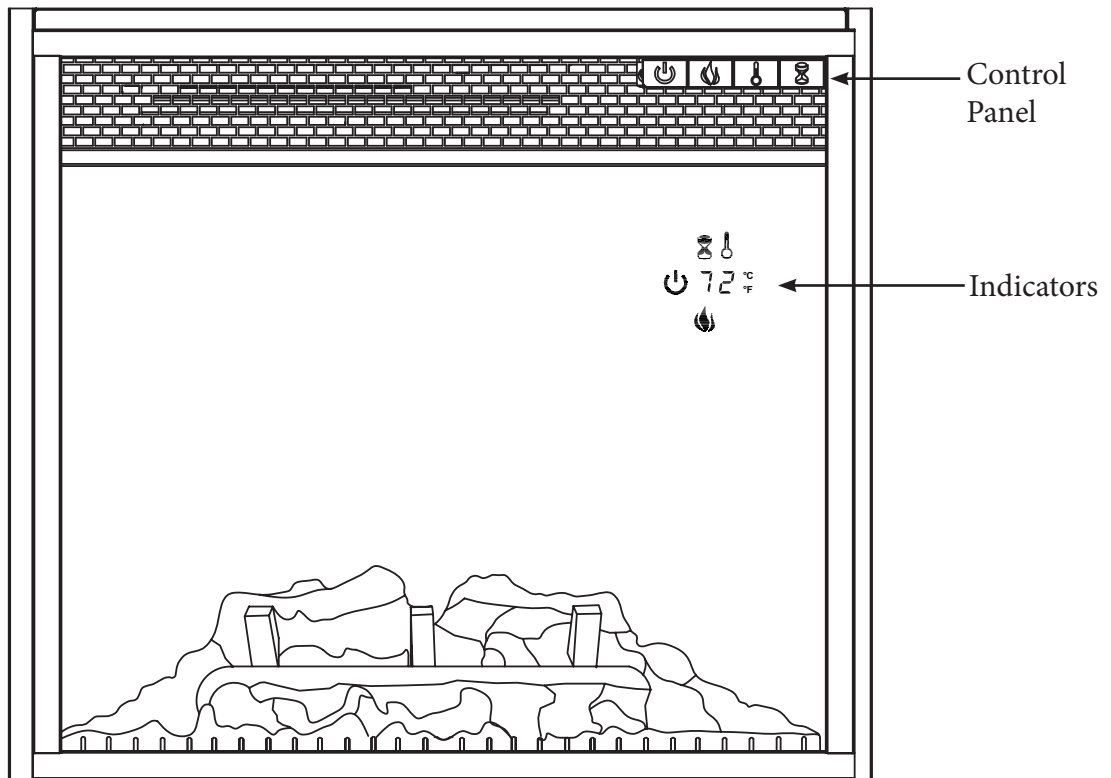

# OPERATION INSTRUCTIONS

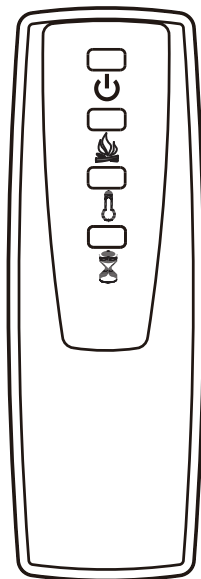

When a function is changed from the control panel or remote there will be a corresponding indicator. The indicator shows the function changed and the level selected. When the function is turned off, the corresponding indicator will flash several times then fade off.



# OPERATION INSTRUCTIONS

FUNCTION	ICON	DESCRIPTION
FLAME		<p>There are 6 brightness levels that can be selected.</p> <p>Settings 6 - 2 decrease in brightness</p> <p>Setting 1 has no blue glow and is full brightness</p>
HEATER		<p>The fireplace contains a fan forced infrared heating elements.</p> <p>The thermostat setting range is 62°F - 82°F or 17°C - 27°C or continuously ON.</p> <p>The button on the remote only turns the heater on/off to the thermostat setting selected with the control panel.</p> <p>To change between °F and °C press and hold the HEATER button on the control panel for 10 seconds.</p>
TIMER		<p>Pressing the timer button will cycle through the timer settings; 30 minutes, 1 Hour, 2H, 3H, 4H, 5H, 6H, 7H, 8H, 9H and off.</p>

# TROUBLESHOOTING

Problem	Root Cause	Corrective Action
Display shows "E1"	The thermostat sensor is broken or disconnected.	Unplug the fireplace, remove the back panel of the fireplace and check that the thermostat is plugged into the main circuit board. If this does not solve the problem contact customer service for a replacement thermostat sensor.
Display shows "E2"	The thermostat sensor is broken.	Contact customer service for a replacement thermostat sensor.
Display shows "E3"	Manual Reset overheat protection has triggered.	Inspect the heater and check that the air inlets and outlets are not blocked as this may cause overheating. Unplug the heater for 5 minutes and allow it to cool down. Replug and operate, monitor the heater for signs of overheating, if the problem persist discontinue use of the heater and contact customer service.
No power, logs do not glow.	No power to the unit	Check that unit is plugged into a standard 120V outlet. Press power button several times, make sure power is set at "ON" position.
Logs glow, but no flame effect.	Flame effect turned off.	Press flame button several times.
Unit continues to run after reaching set temperature/or powering off.	Cool down cycle	Normal operation, will continue to run for less than a minute before shutting down. Times will vary based on heat time. UNIT WILL BLOW COOL AIR.
Power cord gets warm	Normal operation.	Check your heater cord and plug connections. Faulty wall outlet connections or loose plugs can cause the outlet or plug to overheat. Be sure the plug fits tight in the outlet. Heaters draw more current than small appliances, overheating of the outlet may occur even if it has not occurred with the use of other appliances. During use check frequently to determine if your plug outlet or faceplate is HOT! If so, discontinue use of the heater and have a qualified electrician check and/or replace the faulty outlet(s).
Heater does not blow warm air.	Thermostat setting is preventing heater from turning on.	Adjust the temperature settings to ensure that the thermostat is set higher than the current room temperature.
Flame effect works but heater function does not and the emberbed flashes when the heater button is pressed.	The heater is disabled.	With the power on press and hold the POWER button on the control panel for 10 second. Once re-enabled the emberbed lights will flash multiple times.
Remote Control is not working.	No batteries or poor signal.	Change the remote batteries. Operate remote transmitter at a slow measured pace. Press the remote control buttons with an even motion and gentle pressure. Repeatedly pressing buttons in rapid succession may cause the transmitter to malfunction.

# EXPLODED VIEW

Part	Part Name
1	Emberbed with Log
2	Emberbed Circuit Board
3	Front Projection Screen
4	Flame Generator Drive Motor
5	Flame Generator/ Spinner
6	Blue Flame Circuit Board
7	Flame Circuit Board
8	LCD back display
9	Main circuit board
10	Blower assembly
11	Control panel circuit board
12	Control panel buttons
13	Remote Control

Note, the scale and size of your parts may be different depending on your exact model.

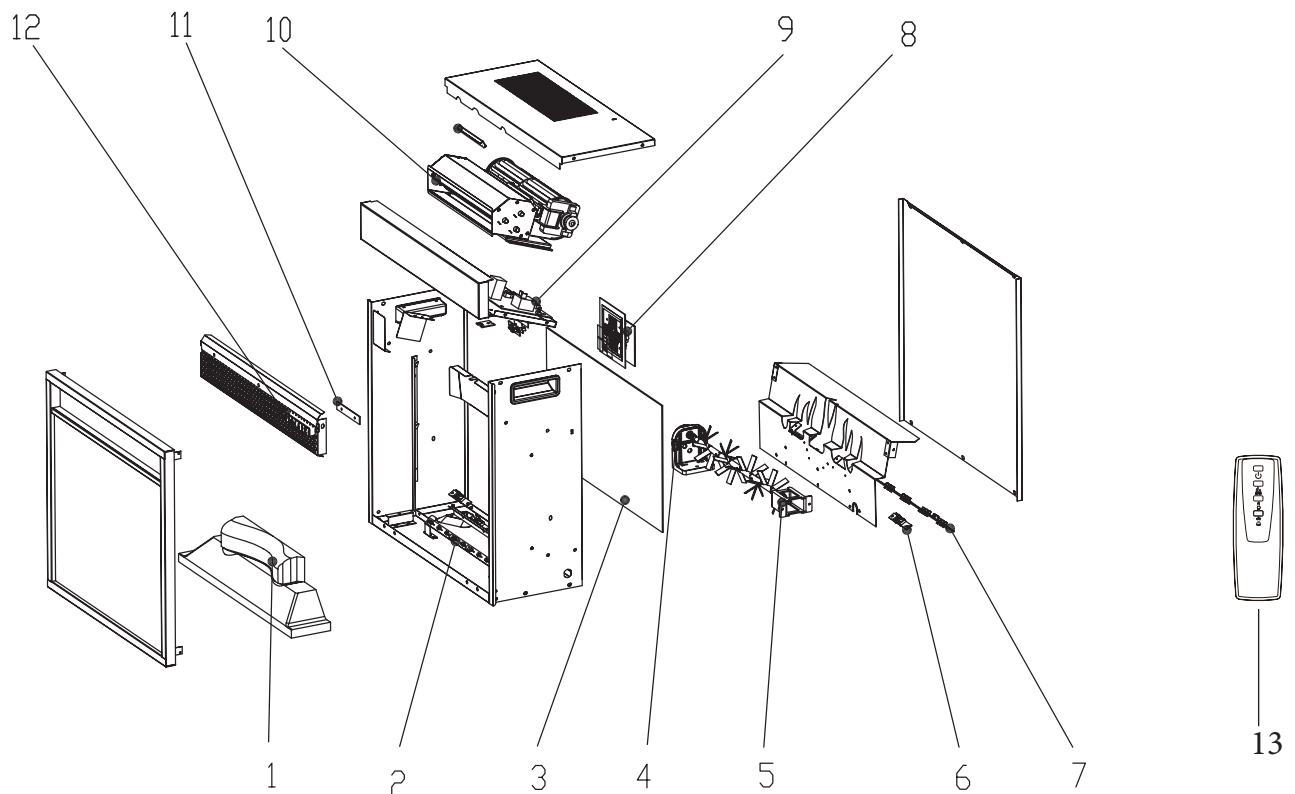

# CARE AND MAINTENANCE

- The motors used on the fan and the flame generator assembly are pre-lubricated for extended bearing life and require no further lubrication. However, we recommend periodic cleaning/vacuuming of the fan/heater.
- Make sure the unit is turned OFF and unplugged before cleaning the heater or fireplace.

# FCC/IC INFORMATION

NOTE: This equipment has been tested and found to comply with the limits for Class B digital device, pursuant to part 15 of the FCC Rules. These limits are designed to provide reasonable protection against harmful interference in a residential installation. This equipment generates, uses, and can radiate radio frequency energy and, if not installed and used in accordance with the instructions, may cause harmful interference to radio or television reception, which can be determined by turning the equipment off and on, the user is encouraged to try to correct the interference by one or more of the following measures:

- Reorient or relocate the receiving antenna.
- Increase the separation between the equipment and the receiver.
- Connect the equipment into an outlet on a circuit different from that to which the receiver is connected.
- Consult the dealer or an experienced radio/TV technician for help.

This device complies with Part 15 of the FCC Rules. Operation is subject to the following two conditions:

- (1) This device may not cause harmful interference, and
- (2) this device must accept any interference received, including interference that may cause undesired operation.

Modifications not approved by the party responsible for compliance could void user's authority to operate the equipment.

This Class B digital apparatus complies with Canadian ICES-003.

# BATTERY REPLACEMENT

NOTE: Do not mix old and new batteries.

Do not mix alkaline, standard (carbon zinc), or rechargeable (nicad, nimh, etc.) batteries.

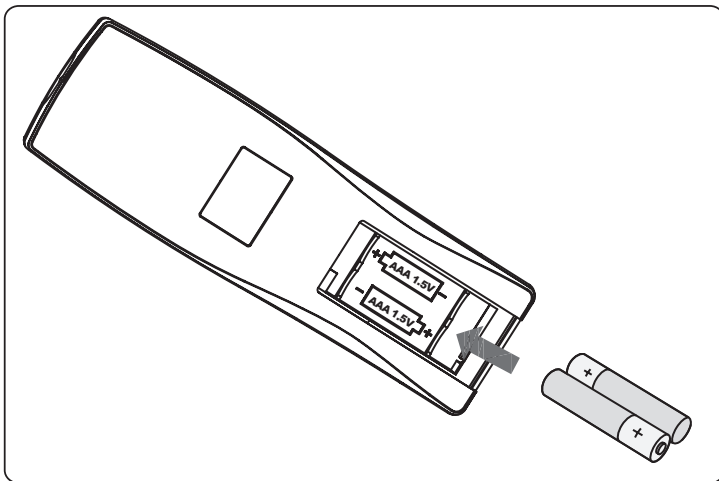

## Note:

### Battery disposal

Please always dispose of batteries at a suitable recycling point.

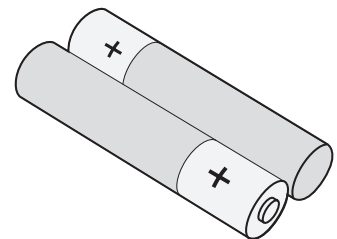

Caution: Do not ingest batteries.

1. Non-rechargeable batteries are not to be recharged.
2. Batteries are to be inserted with the correct polarity.
3. Exhausted batteries are to be removed from the product.



# 1-YEAR LIMITED WARRANTY

---

The manufacturer warrants that your new Electric Fireplace is free from manufacturing and material defects for a period of one year from date of purchase, subject to the following conditions and limitations.

1. Install and operate this appliance in accordance with the installation and operating instructions furnished with the product at all times. Any unauthorized repair, alteration, willful abuse, accident, or misuse of the product shall nullify this warranty.
2. This warranty is non-transferable, and is made to the original owner, provided that the purchase was made through an authorized supplier of the product.
3. The warranty is limited to the repair or replacement of part(s) found to be defective in material or workmanship, provided that such part(s) have been subjected to normal conditions of use and service, after said defect is confirmed by the manufacturer's inspection.
4. The manufacturer may, at its discretion, fully discharge all obligations with respect to this warranty by refunding the wholesale price of the defective part(s).
5. Any installation, labor, construction, transportation, or other related costs/expenses arising from defective part(s), repair, replacement, or otherwise of same, will not be covered by this warranty, nor shall the manufacturer assume responsibility for same.
6. The owner/user assumes all other risks, if any, including the risk of any direct, indirect or consequential loss or damage arising out of the use, or inability to use the product, except as provided by law.
7. All other warranties – expressed or implied – with respect to the product, its components and accessories, or any obligations/liabilities on the part of the manufacturer are hereby expressly excluded.
8. The manufacturer neither assumes, nor authorizes any third party to assume on its behalf, any other liabilities with respect to the sale of the product.
9. The warranties as outlined within this document do not apply to non accessories used in conjunction with the installation of this product.
10. This warranty gives you specific legal rights, and you may also have other rights which vary from state to state.

This warranty is void if:

- a. The fireplace is subjected to prolonged periods of dampness or condensation.
- b. Any unauthorized alteration, willful abuse, accident, or misuse of the product.
- c. You do not have the original receipt of purchase.

## CUSTOMER SERVICE

---

[www.tsicustomerservice.com](http://www.tsicustomerservice.com)

For Customer Service Call 1-800-318-9373

Questions? Our experts are standing by to assist you at our Toll-Free help line, we can help you with assembly, and, if necessary replace damaged/missing parts. Assistance is available 7 days a week/24 hours a day/365 days per year.

**IMPORTANT:**

Before contacting Customer Service please have this information available:

- Serial Number
- Model Number
- Sales Receipt or Proof of Purchase



[www.tsicustomerservice.com](http://www.tsicustomerservice.com)