



CIA PROFESSIONAL SERIES™

# Owner's Manual

Read and save these instructions



Vita-Mix® Corporation  
8615 Usher Road  
Cleveland, OH 44138-2103 U.S.A.  
1.800.848.2649/ 1.440.235.4840  
**[vitamix.com](http://vitamix.com)**

# CONTENTS

Contents .....	2
Let's Get Started .....	3
Symbols .....	3
Service and Registration.....	4
Important Safeguards .....	5
Parts and Features .....	7
Control Panel .....	9
About the Blades .....	10
Tamper .....	11
How to Use the Tamper.....	12
Hints for Setting Speeds.....	13
Operating Instructions .....	14
Care and Cleaning .....	16
Troubleshooting.....	18
Warranty.....	19
Notes.....	22
Specifications .....	24

# LET'S GET STARTED

## **Congratulations!**

You are about to see how quick, easy and delicious healthy eating can be!

### **Before first use:**

1. Please read all the safety information, warnings and instructional material found in this booklet.
2. Set your Vitamix machine on a dry, level surface.
3. Carefully remove the cable tie on the power cord.
4. Make sure the power switch is set to Off. Plug the machine into an grounded electrical outlet.
5. Follow the cleaning instructions on page 16 to prepare your machine for use.

## SYMBOLS



**Warning**



**Read and understand owner's manual**



**Electrical shock hazard**



**Unplug while not in use, before cleaning, changing accessories or approaching parts that move in use**



**Never touch moving parts**



**Do not immerse or place the motor base in water**



**Hot surface - DO NOT touch**

# SERVICE AND REGISTRATION

## Vitamix Service

Record the model number and serial number of your Vitamix in the spaces provided below for future reference. These numbers can be found on the back of the motor base.

Model Number \_\_\_\_\_

Serial Number \_\_\_\_\_

Date of Purchase \_\_\_\_\_

Purchased From \_\_\_\_\_

Before returning this product for any reason, including repair, first contact Vitamix Customer Service at 1.800.848.2649 or 1.440.235.4840, email [service@vitamix.com](mailto:service@vitamix.com), or contact your local dealer.

## Product Registration

If you purchased your Vitamix® machine directly from the Vita-Mix® Corporation via the company's website or call center by phone, your product was registered at the time of purchase and your Vitamix machine's warranty has been activated.

If you purchased your Vitamix machine from an International Distributor or Dealer in countries other than the United States, Canada, United Kingdom, or Ireland, your product is warranted through the International Distributor or Dealer and need not be registered with the Vita-Mix Corporation.

### Your machine is not yet registered with Vitamix if you:

1. Purchased from a Dealer in the United States, Canada, United Kingdom, or Ireland
2. Purchased from a military base
3. Purchased from a retail or wholesale store
4. Received your Vitamix machine as a gift
5. Are not the original owner of the machine

Enjoy faster and easier service in the future by taking a few minutes to register your Vitamix machine today.

### Choose one of these easy ways to register your machine:

1. Online at [vitamix.com/warranty](http://vitamix.com/warranty)
2. Email [service@vitamix.com](mailto:service@vitamix.com)
3. Call 1.800.848.2649 or 1.440.235.4840

Your warranty may be honored by Vita-Mix® Corporation or an authorized dealer.

Failure to register your machine will not diminish your warranty rights.

# IMPORTANT SAFEGUARDS



**WARNING:** To avoid the risk of serious injury when using your Vitamix® blender, basic safety precautions should be followed, including the following.

## **READ ALL INSTRUCTIONS, SAFEGUARDS, AND WARNINGS BEFORE OPERATING BLENDER.**

1. Read all instructions.
2. Not intended for use by or near children or persons with reduced physical, sensory, or mental capabilities or lack of experience and knowledge. Close supervision is necessary when any appliance is used by or near children or incapacitated persons.
3. To protect against the risk of electrical shock, do not put the blender base in water or other liquid.
4. Unplug from outlet when not in use, before putting on or taking off parts, and before cleaning.
5. Avoid contacting moving parts.
6. Do not operate any appliance with a damaged cord or plug or after the appliance malfunctions, or is dropped or damaged in any manner. Call Vitamix Customer Service at 1.800.848.2649 or 1.440.235.4840 or email [service@vitamix.com](mailto:service@vitamix.com) at once for examination, repair, replacement, or electrical or mechanical adjustment. If purchased outside the U.S.A. or Canada, contact your local Vitamix dealer.
7. Alteration or modification of any part of the blender base or container, including the use of any part or parts that are not genuine authorized Vitamix parts, may cause fire, electric shock, or injury.
8. The use of attachments not expressly authorized or sold by Vitamix for use with this blender, including canning jars, may cause fire, electric shock, or injury.
9. Do not use outdoors.
10. Do not let cord hang over edge of table or counter.
11. Do not let cord contact hot surface, including the stove.
12. Keep hands and utensils out of container while blending to reduce the risk of severe injury to persons or damage to the blender. A rubber scraper or spatula may be used, but only when the Vitamix blender is not running.
13. The tamper provided must be used only when the main part of the lid is in place.
14. Blades are sharp. Handle or remove blade and blade assembly from the container with extreme care to avoid injury. To reduce the risk of injury, never place a blade assembly on the motor base unless assembled to the Vitamix container.
15. Do not leave foreign objects, such as spoons, forks, knives or the lid plug, in the container as this will damage the blades and other components when starting the machine and may cause injury.
16. Never attempt to operate with damaged blades.

# IMPORTANT SAFEGUARDS

17. Always operate blender with lid and lid plug firmly in place. The lid plug should be removed only when adding ingredients and when using the tamper.
18. When blending hot liquids or ingredients, use caution; spray or escaping steam may cause scalding and burns. Do not fill container to the maximum capacity. Always begin processing on the lowest speed setting, variable speed 1. Keep hands and other exposed skin away from the lid opening to prevent possible burns.
19. When making nut butters or oil-based foods, do not process for more than one minute after the mixture starts to circulate in the container. Processing for longer periods can cause dangerous overheating.

## SAVE THESE INSTRUCTIONS

### ⚠ WARNING



#### To Avoid Injury.

Read and understand instruction manual before using this machine.



## IMPORTANT INSTRUCTIONS FOR SAFE USE

This product is intended for HOUSEHOLD USE ONLY and is not intended to be used for commercial purposes.

Do not leave your Vitamix blender unattended when operating.

Any repair, servicing, or the replacement of parts must be performed by Vitamix or an authorized service representative.

### ⚠ WARNING



#### Electrical Shock Hazard.

Use grounded outlet only.

**DO NOT** remove ground.

**DO NOT** use an adapter.

**DO NOT** use an extension cord.

Always unplug before cleaning the motor base or when not in use.

Do not put the motor base in water or other liquid.

**Failure to follow instructions can cause death or electrical shock.**



**NOTICE:** THE FAILURE TO FOLLOW ANY OF THE IMPORTANT SAFEGUARDS AND THE IMPORTANT INSTRUCTIONS FOR SAFE USE IS A MISUSE OF YOUR VITAMIX BLENDER THAT CAN VOID YOUR WARRANTY AND CREATE THE RISK OF SERIOUS INJURY.

# PARTS AND FEATURES



**1 On/Off Switch:** Always start the machine with the High/Variable switch in the Variable ( $\triangle$ ) position and the Variable Speed Dial pointed to 1. Lift the On/Off Switch to the On position (I) to begin blending. Press the switch to the Off position (O) to stop blending.

**2 Control Panel:** For more information, refer to Control Panel on Page 9.

**!** **CAUTION:** Lids and tampers are not interchangeable between different container styles, types and sizes. Refer to Tamper on Page 11.

**3 64-oz. capacity container with 2-part lid:**

- Always use the lid and the lid plug when the machine is in operation
- Never operate the blender without checking to make sure that the lid is securely locked in place.
- Ounces, Milliliters and Cups are clearly marked.
- Insert the lid plug through the lid and secure by turning clockwise.
- Remove the lid plug to use the tamper or to add ingredients.

**4 Tamper:** Using the tamper maintains circulation by preventing air pockets from forming during blending.

*Parts and Features continues on page 8*

# PARTS AND FEATURES

## ⚠ WARNING



### **Rotating Blades Can Cause Severe Injury.**

**DO NOT** reach into the container while the machine is running.



**To Lock the Lid in Place:** Position the lid on the container with the lid flaps midway between the spout and the handle. Push the lid onto the container until it locks into place. The lid must always be secured when processing, especially when blending hot liquids that may scald. **Never operate the blender without checking to make sure that the lid is securely locked in place.**

**To Remove the Lid:** Lift up on one lid flap, while holding the container securely.

**To Remove the Lid Plug:** Rotate the lid plug anti-clockwise from the “locked” to the “unlocked” position and lift out.

**Power Cord:** Your machine is equipped with a long power cord. Store the unused portion neatly underneath. Plastic cable retainers hold the cord securely. They are flexible and return to position after the cord is lifted out.

**Bottom View / Cord Wrap:** Plastic cord retainers hold the cord securely. There is no need to unscrew the cord retainers to let out more cord. They are flexible, and return to position after the cord is lifted out.

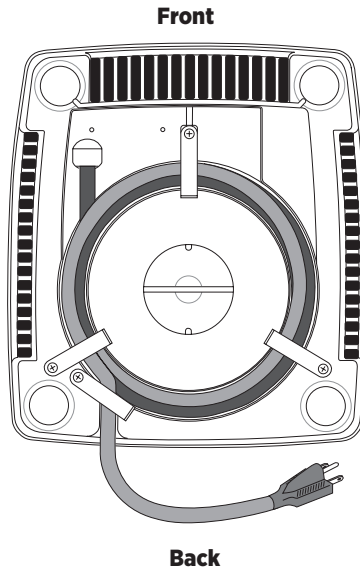

# CONTROL PANEL

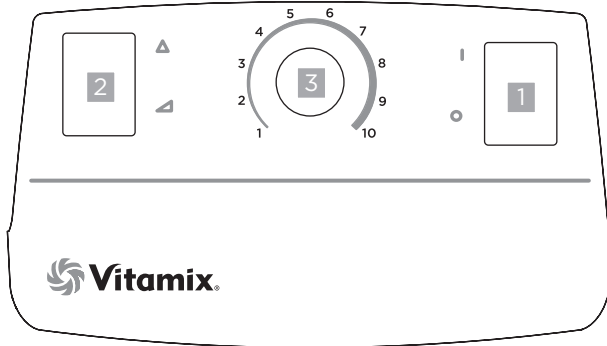

- 1. On/Off Switch:** Push up to turn On (I). Push down to turn Off (O).
- 2. High/Variable Switch:** High (Δ) is the fastest speed available. Switch to Variable (∟) to activate the variable speeds. **Always make sure that the High/Variable Switch is set to Variable (∟) before lifting the On/Off Switch to the On (I) position.** Do not start your machine on High (Δ) speed.
- 3. Variable Speed Dial:** Selects many speed settings. It is active only when the High/Variable Switch is set in the Variable (∟) position.

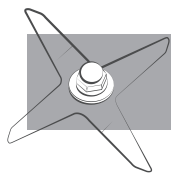

## ABOUT THE BLADES

The wet-blade container comes as standard with the Vitamix machine. The blade is identified by a “W” for wet. This blade is used for most of your recipes. Additional containers with wet or dry blades may be purchased separately.

### ⚠ WARNING



#### **Rotating Blades Can Cause Severe Injury.**

**DO NOT** reach into the container while the machine is running.

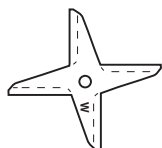

**Wet-Blade Container:** Designed for processing liquids, including juice, frozen mixtures, sauces, soup, purées, batter, and for wet chopping. The wet blades can also process grain and knead dough, but they are not quite as efficient as the dry blades in this application. See instructions for dry container use.

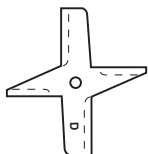

**Dry-Blade Container:** These blades are clearly marked “D” and are designed specifically for processing dry materials such as grain, cereal and coffee, and are also used for kneading bread dough. The dry blades **CANNOT** process liquids efficiently. **If you prepare herbs on a regular basis, you may wish to purchase a separate dry-blade container.**

### ⚠ CAUTION



#### **Moving Parts May Become Hot with Extended Use.**

**DO NOT** touch.



# TAMPER

## ⚠ CAUTION





### Rotating Blades Can Cause Damage.

Lids and tampers are not interchangeable between different container styles, types and sizes. Use the tamper that was supplied with your machine.

## How to Determine the Tamper to be Used with Your Container

Before using a tamper during the blending process, verify that you have the correct tamper. **If a tamper came with your machine and container at purchase, it is the correct tamper to use.** If a tamper did not come with your container or you want to determine if a tamper that you already have can be used with your new container, please see the inspection steps and illustration below.

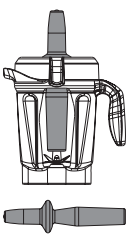
1. Place the lid on an empty container.
2. Remove the lid plug and insert the tamper. The tamper should fit easily into the opening. It should not come into contact with the blades no matter where you move the tamper inside the container
3. Visually inspect: **IF THE TAMPER TOUCHES THE BLADES AT ANY ANGLE, DO NOT USE THE TAMPER WITH YOUR CONTAINER.**
4. If you do not have the correct tamper for your container, contact Vitamix Household Customer Service at 1.800.848.2649 or 1.440.235.4840.

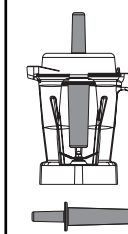
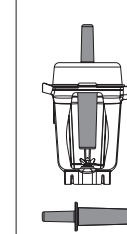
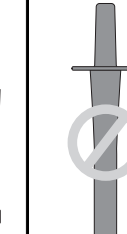
				
<b>64 oz. / 2,0 L (SHORT)</b>	<b>64 oz. / 2,0 L (TALL)</b>	<b>48 oz. / 1,4 L</b>	<b>32 oz. / 0,9 L</b>	
64 oz. / 2 L <b>Short</b> Container uses a tamper which is approx. 11 in. long.	64 oz. / 2 L <b>Tall</b> Container uses a tamper which is approx. 12-½ in. long.	48 oz. (1.4 L) and 32 oz. (0.9 L) Containers use a tamper which is approx. 9-¾ in. long.		A non-step tamper must not be used with any of the containers.

# HOW TO USE THE TAMPER

## ⚠ WARNING



### Rotating Blades Can Cause Severe Injury.

- **DO NOT** put hands, spatulas etc. into the container while the machine is running or while the container is still on the base.
- Lids and tampers are not interchangeable between different container styles, types and sizes. Use the tamper that was supplied with your machine.



## IMPORTANT!

- The splash disk (near the top of the tamper) and lid prevent the tamper from hitting the blades when the lid is secured properly in the locked position.
- The container should not be more than two-thirds full when the tamper is used during blending.
- To avoid overheating during blending, **DO NOT** use the tamper for more than 30 consecutive seconds.
- If the food does not circulate, the machine may have trapped an air bubble. Carefully remove the lid plug, while making sure the lid stays firmly in place. Release the air bubble by inserting the tamper through the lid plug opening.
- Holding the tamper straight down may not help the ingredients circulate. If necessary, point the tamper towards the sides or corners of the container. **DO NOT** try to force the tamper more deeply into the container.

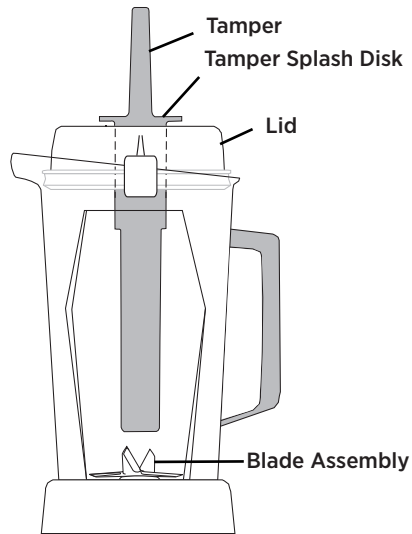

## HINTS FOR SETTING SPEEDS

### ⚠ CAUTION



**To Avoid Possible Burns, Never Start on Speeds Above 1 when Processing Hot Liquids. Always start on Variable 1, then slowly increase to 10.**



Escaping steam, splashes or contents may scald.

To secure the contents, lock the lid and lid cap securely in place prior to operating the machine.

**To minimize splatter, always start with the High/Variable Switch in the Variable (◁) position and with the center Variable Speed Dial pointed at 1. Do not begin processing on Variable 10 or directly on the High (Δ) setting.**

Activate the machine by turning the On/Off Switch to On (I) and slowly turn the Variable Speed Dial to the desired speed depending on the recipe used. If a recipe calls for processing on High (Δ), slowly rotate the Variable Speed Dial to 10 and then push the High/Variable Switch up into the High (Δ) position.

Process on the High (Δ) setting for as much of the processing time as possible to make whole food juices, soups, shakes, frozen mixtures, purées, nut butters and for grinding grains. Processing times will generally be less than one minute (most take less than 30 seconds). High (Δ) speed provides the best quality of refinement, breaking down ice, frozen fruit, whole fruits or vegetables, and grains to a smooth lump-free consistency.

**TIP:** Blending too long at too low a speed setting will overheat the machine and cause the Automatic Overload Protection to turn the machine off. Use the High (Δ) speed as often as possible to achieve the most uniform consistency. Blending on High (Δ) speed also maximizes the motor's cooling fan to avoid overheating.

When on High (Δ), if the food does not circulate, the machine may be overloaded or may have trapped an air bubble. Carefully remove the lid plug while making sure the lid stays firmly in place. Release the air bubble by inserting the tamper through the lid plug opening. If circulation problems continue, reduce the machine speed. A lower speed may allow food to circulate when a higher speed does not. Once the food is circulating freely, increase the speed back to High (Δ) and continue processing.

# OPERATING INSTRUCTIONS

## ⚠CAUTION



**To Avoid Possible Burns, Never Start on Speeds Above 1 when Processing Hot Liquids. Always start on Variable 1, then slowly increase to 10.**

Escaping steam, splashes or contents may scald.

To secure the contents, lock the lid and lid cap securely in place prior to operating the machine.

**To minimize splatter, always start with the High/Variable Switch in the Variable (◁) position and with the center Variable Speed Dial pointed at 1. Do not begin processing on Variable 10 or directly on the High (Δ) setting.**

1. Before you begin, look at the control panel. Make sure that the Variable Speed Dial is set to 1.
2. Load the ingredients into the container according to the recipe.
3. Securely fasten the 2-part lid to the container. Always use the complete 2-part lid when blending (unless the tamper is inserted through the lid plug opening). When blending with hot ingredients, make sure the lid is securely latched.
4. With the motor off, set the container on the motor base by aligning it on the centering pad. Do not attempt to put a container on an operating motor base or to operate a motor base without a container properly in place.
5. Always start with the High/Variable Switch in the Variable (◁) position and with the center Variable Speed Dial pointed at 1. Do not begin processing on Variable 10 or directly on the High (Δ) setting. Activate the machine by switching the On/Off Switch to On (I) then slowly turn the Variable Speed Dial to the desired speed called for in the recipe. If a recipe calls for processing on High (Δ), slowly rotate the Variable Speed Dial to 10 and then push the High/Variable Switch up into the High (Δ) position.

**Loading the Container**

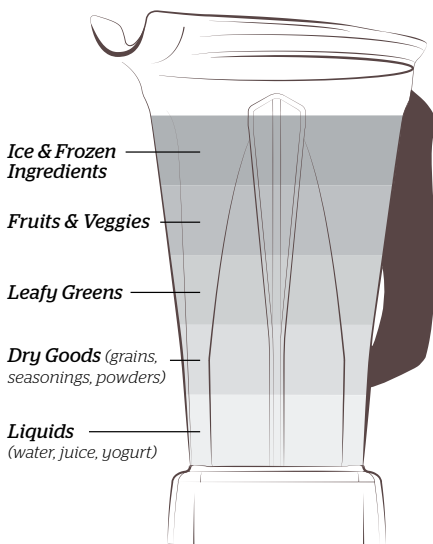

# OPERATING INSTRUCTIONS

6. Take proper care when handling and processing hot ingredients and making hot soups and sauces.

## ⚠ CAUTION



**To Avoid Possible Burns, Never Start on Speeds Above 1 when Processing Hot Liquids. Always start on Variable 1, then slowly increase to 10.**

Escaping steam, splashes or contents may scald.

To secure the contents, lock the lid and lid cap securely in place prior to operating the machine.



**To minimize splatter, always start with the High/Variable Switch in the Variable (⚡) position and with the center Variable Speed Dial pointed at 1. Do not begin processing on Variable 10 or directly on the High (Δ) setting.**

7. Due to the machine's speed, processing times are much quicker than standard appliances. Until you are accustomed to the machine, count your time carefully to avoid over processing.
8. After turning the machine off, wait until the blades completely stop before removing the lid or container from the motor base.

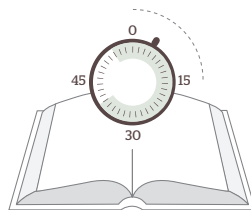

### ***IMPORTANT NOTES ABOUT USE OF THE DRY CONTAINER:***

- Grinding dry material for more than two minutes could damage your machine.
- Regular use may result in cosmetic marring of the container and cause the blades to become dull over time.
- Grinding some herbs may release oils, causing the container to discolor permanently.
- Others have strong odors that may linger in the container, affecting the flavor of other foods.
- The grinding of some herbs and spices may also cause the blade to dull over time, or the container to crack.

# CARE AND CLEANING

To prepare your new machine for initial use, follow the steps under Normal Cleaning, below. This will clean the unit and break in the motor.

***During your first few uses, you may notice a slight burning odor as the motor is primed. This is completely normal and will dissipate quickly.***

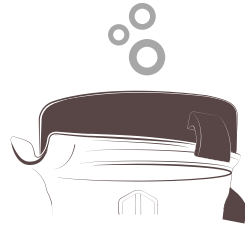

## **Container**

To prepare your new machine for initial use, follow the steps under Normal Cleaning below. This will clean the unit, and break-in the motor.

### **Normal Cleaning:**

1. Fill the container half full with warm water and add a couple drops of liquid dish washing detergent to the container.
2. Snap or push the complete 2-Part lid into locked position.
3. Select variable speed 1. Turn machine on and slowly increase speed to variable speed 10, then to High.
4. Run the machine on High speed for 30 to 60 seconds.
5. Turn off the machine, and rinse and drain the container.

### **To Sanitize:**

1. Follow Normal Cleaning instructions above.
2. Fill the container half full with water and 1 ½ teaspoons of liquid bleach.
3. Snap or push the complete 2-Part lid into locked position.
4. Select variable speed 1. Turn machine on and slowly increase speed to variable speed 10, then to High.
5. Run the machine on High speed for 30 to 60 seconds.
6. Turn off the machine, and allow mixture to stand in the container for an additional 1 ½ minutes.
7. Pour bleach mixture out. Allow container to air dry.
8. Do not rinse after sanitizing.

## **Lid, Lid Plug and Tamper**

Separate the lid and lid plug. Wash the parts in warm soapy water. Rinse clean under running water, and dry. Reassemble before use.

**IMPORTANT:** To ensure continued and effective performance, do not put the container, lid, lid plug or tamper in the dishwasher.

# CARE AND CLEANING

## **Motor Base**

1. Unplug the power cable.

### **⚠ WARNING**



#### **Electrical Shock Hazard.**

Always unplug before cleaning the motor base or when not in use.

Do not put the motor base in water or other liquid.

**Failure to follow instructions can cause death or electrical shock.**



2. Wash the outside surface with a damp, soft cloth or sponge that has been rinsed in a mild solution of washing-up liquid and warm water. Do not place the motor base in water.
3. The centering pad can be removed for more thorough cleaning.
4. Thoroughly clean the switches so that they work freely. They may become sticky from use. Moisten a cotton bud with a household degreaser or cleaner and clean the grooves around the switches. Immediately dry all surfaces.
5. Polish with a soft cloth.

## **Retainer Nut Loosening**

In the event that the retainer nut at the bottom of your container loosens and no longer holds the blade assembly securely in place, **DO NOT CONTINUE TO USE THE CONTAINER.** Contact Vitamix customer service immediately for instructions.

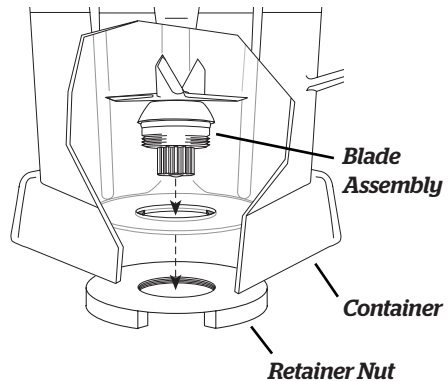

# TROUBLESHOOTING

Your Vitamix motor is designed to be protected from overheating during use. This feature will shut off the motor. The motor will possibly emit a slight odor. If the motor shuts off due to overheating while blending, allow the machine to cool for 20-45 minutes before beginning another blending cycle. If you continue to experience problems after following these instructions, contact our Customer Service Department at 1.800.848.2649 or 1.440.235.4840 for instruction.

## **Tips to prevent “overloading” your Vitamix machine:**

- Only process Vitamix recipes when learning to use the machine
- Do not process recipes at lower speeds than those recommended
- Do not process recipes at higher speeds than those recommended
- Do not process recipes for longer than recommended
- Use your tamper to process thicker mixtures and keep ingredients moving around and through the blades

# WARRANTY

## **7-Year Full Machine Warranty**

### **1. PRODUCT REGISTRATION.**

Vita-Mix® Corporation (“Vitamix”) strongly encourages you to register your purchase by completing and returning the product registration card that came with this Machine. You can register online at [vitamix.com/warranty](http://vitamix.com/warranty); or by calling our Customer Service Department at 1.800.848.2649 or 1.440.235.4840. Failure to register your product purchase will not diminish your warranty rights. However, registering your purchase will allow Vitamix to better serve you with any of your customer service needs.

### **2. WHO CAN SEEK WARRANTY COVERAGE.**

This Warranty is extended by Vitamix to the owner of this Machine for personal household use only. This Warranty does not apply to products used for commercial, rental or re-sale purposes. Should ownership of the machine change during the 7-year period, please update the Machine’s owner information at [vitamix.com/warranty](http://vitamix.com/warranty).

### **3. WHAT IS COVERED.**

Vitamix warrants to the owner that if this Machine (a “Machine” consists of a motor blender base and any containers purchased together) fails within 7 years from the date of purchase due to a defect in material or workmanship or as a result of normal wear and tear from ordinary household use, Vitamix will, within 30 days of receipt of the returned product, repair the failed Machine or component part of the Machine free of charge.

If, in Vitamix’s sole discretion, the failed Machine or component part of the Machine cannot be repaired, Vitamix will elect to either (A) replace the Machine free of charge or (B) refund the full purchase price to the owner, unless Vitamix receives prior written notice of the owner’s preference.

### **4. WHAT IS NOT COVERED.**

This Warranty does not apply to Machines that have been used commercially or in non-household applications. This Warranty does not cover cosmetic changes that do not affect performance, such as discoloration or the effects of the use of abrasives or cleaners or food build up. This Warranty is only valid if the Machine is used and maintained in accordance with the instructions, warnings and safeguards contained in the owner’s manual.

Vitamix will not be responsible for the cost of any unauthorized warranty repairs.

# WARRANTY

**REPAIR, REPLACEMENT OR REFUND OF THE PURCHASE PRICE ARE THE EXCLUSIVE REMEDIES OF PURCHASER AND THE SOLE LIABILITY OF VITAMIX UNDER THIS WARRANTY. NO EMPLOYEE OR REPRESENTATIVE OF VITAMIX IS AUTHORIZED TO MAKE ANY ADDITIONAL WARRANTY OR ANY MODIFICATION TO THIS WARRANTY WHICH MAY BE BINDING UPON VITAMIX. ACCORDINGLY, PURCHASER SHOULD NOT RELY UPON ANY ADDITIONAL STATEMENTS MADE BY ANY EMPLOYEE OR REPRESENTATIVE OF VITAMIX. IN NO EVENT, WHETHER BASED ON CONTRACT, INDEMNITY, WARRANTY, TORT (INCLUDING NEGLIGENCE), STRICT LIABILITY OR OTHERWISE, SHALL VITAMIX BE LIABLE FOR ANY SPECIAL, INDIRECT, INCIDENTAL OR CONSEQUENTIAL DAMAGES, INCLUDING, WITHOUT LIMITATION, LOSS OF PROFIT OR REVENUE.**

Some states do not allow limits on warranties. In such states, the above limitations may not apply to you. Outside the U.S.A. and Canada, other warranties may apply.

## **5. WHAT VOIDS THIS WARRANTY.**

Abuse, misuse, negligent use, alteration of the Machine, exposure to abnormal or extreme conditions, or failure to follow the operating instructions will void this Warranty.

The Warranty is also void if repairs to the Machine or any component part of the Machine are performed by someone other than either Vitamix or an authorized Vitamix Service Provider or if any component part of a Machine subject to this Warranty is used in combination with a motor base or container that is not expressly authorized by Vitamix.

## **6. HOW TO OBTAIN RETURN AUTHORIZATION UNDER THIS WARRANTY.**

In the event that the Machine or any component part of the Machine needs service or repair, please call Vitamix Customer Service at 1.800.848.2649 or 1.440.235.4840. You will be asked to provide a date of purchase and proof of purchase for any product that has not been registered with Vitamix. For product subject to this Warranty you will be provided with a return authorization number, up-to-date shipping instructions and a pre-paid return pick up label. Vitamix will pay standard shipping costs on the return of a Machine or component part for warranty service and repair and for return shipment of the product to you after the warranty repair or replacement. Purchaser is responsible for the costs of special shipping requests.

Within the U.S.A. and Canada, this Warranty is honored directly through the Vita-Mix® Corporation.

# WARRANTY

**United States**

Vita-Mix® Corporation  
8615 Usher Road  
Cleveland, Ohio 44138-2199  
1.800.848.2649  
service@vitamix.com

**Canada**

Vita-Mix® Corporation  
200-1701 Shepherd Street East  
Windsor, Ontario N8Y 4Y5  
1.800.848.2649  
service@vitamix.com

You will be deemed to have accepted the returned product “as is” upon delivery unless you notify Vitamix of any problem, including shipment damage, within 48 hours of delivery.

**SPECIAL INTERNATIONAL INSTRUCTIONS**

If a machine was purchased within the U.S.A. or Canada, but is currently outside the U.S.A. or Canada, all shipping and resulting taxes and duties are at the owner’s expense.

Call +1.440.235.4840 or email service@vitamix.com for more details.





# SPECIFICATIONS

## CIA Professional Series™

### Motor:

≈ 2 peak output horsepower motor

### Electrical:

120 V, 50 / 60 Hz, 11.5 A

Uses a U.S.A. three-prong grounded cord

### Dimensions:

Height: 20.3 in. / 51.6 cm

Width: 8.8 in. / 22.4 cm

Depth: 9 in. / 22.9 cm

---

When applicable:



To see the complete line of Vitamix® products,  
visit **[vitamix.com](http://vitamix.com)**



Vita-Mix® Corporation  
8615 Usher Road  
Cleveland, OH 44138-2103 U.S.A.  
1.800.848.2649/+1.440.235.4840  
**[vitamix.com](http://vitamix.com)**

©2015 Vita-Mix® Corporation. No part of this publication may be reproduced or transmitted in any form or by any means, or stored in a database or retrieval system, without the written permission of the Vita-Mix® Corporation.