

# duraf<sup>®</sup>flame

MODEL/ MODELE/ MODELO:

DFI-3108-01, DFI-3108-02, DFI-3108-03,  
DFI-3108-04, DFI-3108-05



**TWIN-STAR<sup>®</sup>**  
INTERNATIONAL  
HOME FURNISHINGS

**[www.tsicustomerservice.com](http://www.tsicustomerservice.com)**

Distributed by • Distribuido por • Distribué par • Twin-Star International, Inc; Delray Beach, FL 33445  
Made in China • Printed in China • Fabricado en China • Impreso en China • Fabriqué en China • Imprimé en Chine

Warning: This is an unvented, electric appliance.  
DO NOT attempt to burn wood or manufactured  
firelogs in or on this appliance or grate.

Advertencia: Este es un aparato eléctrico sin  
ventilación. NO intente quemar leños fabricados ni  
madera dentro o sobre este aparato o su parrilla.

Avertissement : Il s'agit d'un appareil électrique  
non ventilé. NE PAS tenter de faire brûler du bois  
ou des bûches fabriquées dans l'appareil ou sur  
la grille.

# IMPORTANT INSTRUCTIONS

When using electrical appliances, basic precautions should always be followed to reduce the risk of fire, electrical shock, and injury to persons including the following:

1. Read all instructions before using this appliance.
2. This appliance is hot when in use. To avoid burns, do not let bare skin touch hot surfaces. If provided, use handles when moving this appliance. Keep combustible materials, such as furniture, pillows, bedding, papers, clothes and curtains at least 3 feet (0.9 m) from the front of this appliance. **WARNING:** In order to avoid overheating, do not cover the heater.
3. **CAUTION:** Never leave the heater operating unattended. Extreme caution is necessary if unsupervised children or invalids are nearby.
4. The appliance is not to be used by children or persons with reduced physical, sensory or mental capabilities, or lack of experience and knowledge, unless they have been given supervision or instruction.
5. Always unplug this appliance when not in use.
6. Do not operate any heater with a damaged cord or plug or after the appliance malfunctions, or if it has been dropped or damaged in any manner.
7. If the supply cord is damaged, it must be replaced by the manufacturer, its service agent or similarly qualified persons in order to avoid a hazard.
8. Do not use outdoors.
9. This heater is not intended for use in bathrooms, laundry areas and similar indoor locations. Never locate this appliance where it may fall into a bathtub or other water container.
10. Do not run cord under carpeting. Do not cover cord with throw rugs, runners or the like. Arrange cord away from traffic areas and where it will not be tripped over.
11. To disconnect this appliance, turn controls to the off position, then remove plug from outlet.
12. Do not insert or allow foreign objects to enter any ventilation or exhaust opening as this may cause an electric shock or fire, or damage the appliance.
13. To prevent a possible fire, do not block air intakes or exhaust in any manner. Do not use on soft surfaces, like a bed, where opening may become blocked.
14. This appliance has hot and arcing or sparking parts inside. Do not use it in areas where gasoline, paint or flammable liquids are used or stored. This stove should not be used as a drying rack for clothing. Christmas stockings or decorations should not be hung in the area of it.
15. Use this appliance only as described in the manual. Any other use not recommended by the manufacturer may cause fire, electric shock or injury to persons.
16. Connect to properly grounded outlets only. See Fig.1. This heater is for use on 120 volts. Do not use a 2 prong adapters. Always plug heaters directly into a wall outlet/receptacle. Never use with an extension cord or relocatable power tap (power strip).

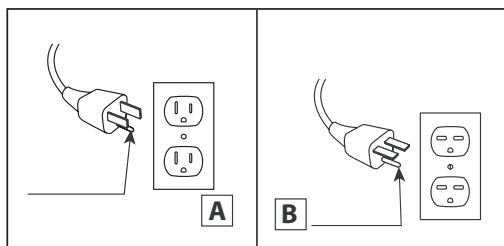
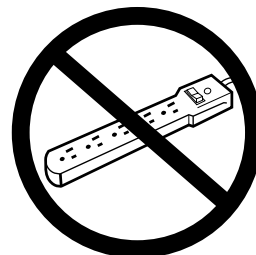

Fig.1



## SAVE THESE INSTRUCTIONS

# GETTING STARTED

1. The serial number is located on the back of the stove, the serial number is necessary for product warranty registration and customer service.

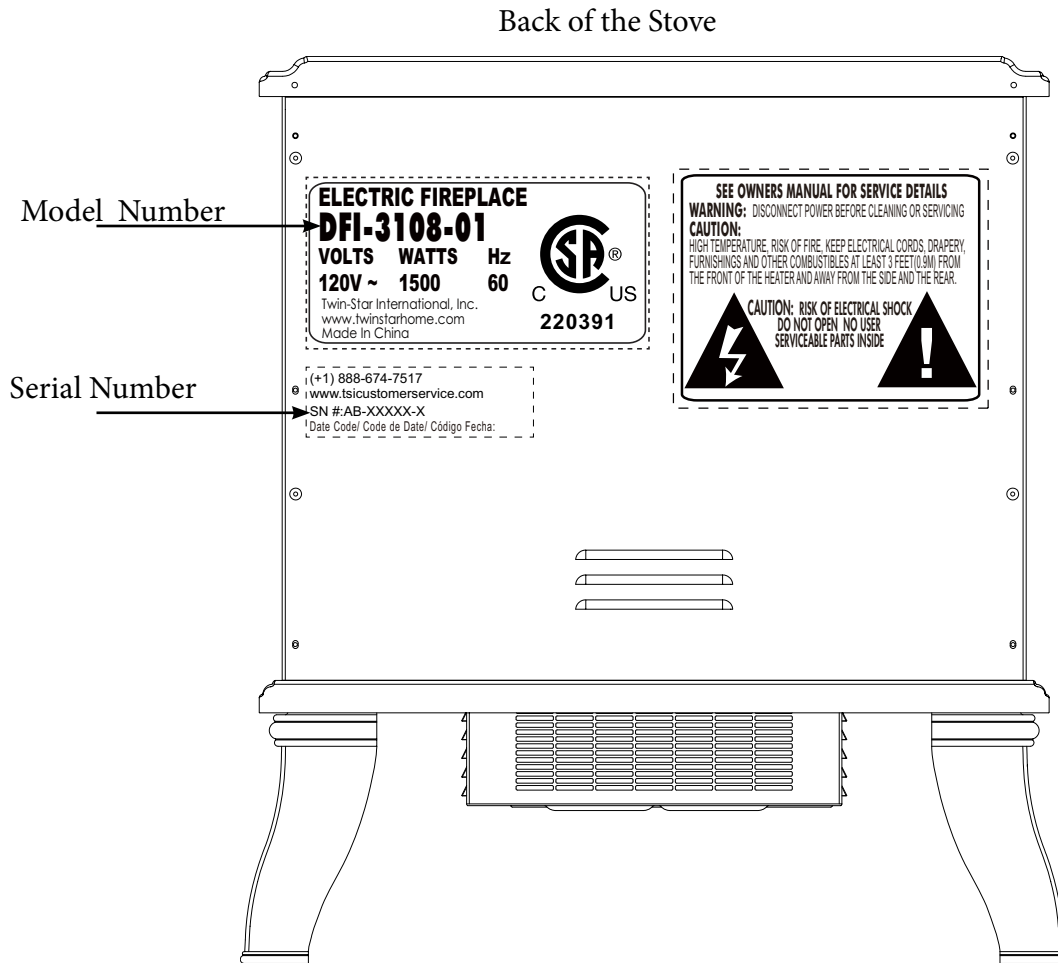

2. Go to [www.tsicustomerservice.com](http://www.tsicustomerservice.com) for product warranty registration. For registration use the **MODEL NUMBER: DFI-3108-01 or DFI-3108-02 or DFI-3108-03 or DFI-3108-04 or DFI-3108-05**. If you are unable to complete registration save your proof of purchase for warranty purposes.

## PRODUCT SPECIFICATIONS

VOLTAGE	120VAC, 60 Hz
AMPS	12.5 Amps
WATTS (max.)	1500 Watts

# INSTALLATION INSTRUCTIONS

## Tools Required for Assembly

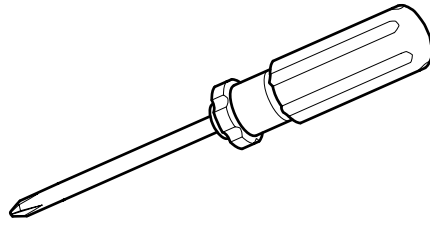

Phillips Head Screwdriver

## Leg Assembly

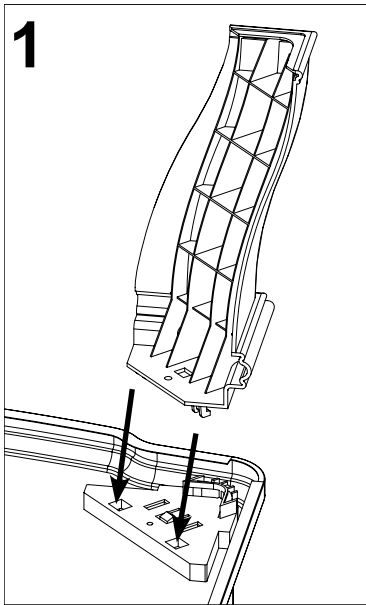

1  
Align the 2 mounting tabs into the bracket.

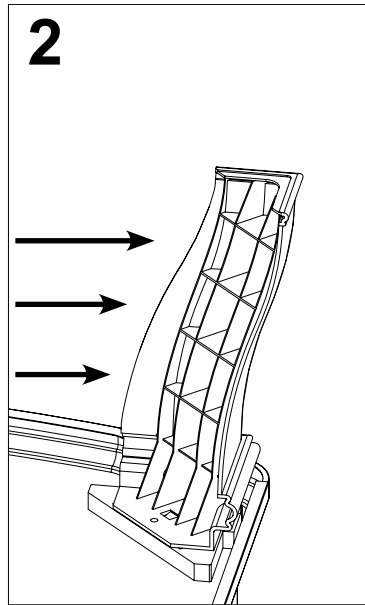

2  
Slide the legs outward to lock in place. When locked in position the screw hole from step 3 will be aligned.

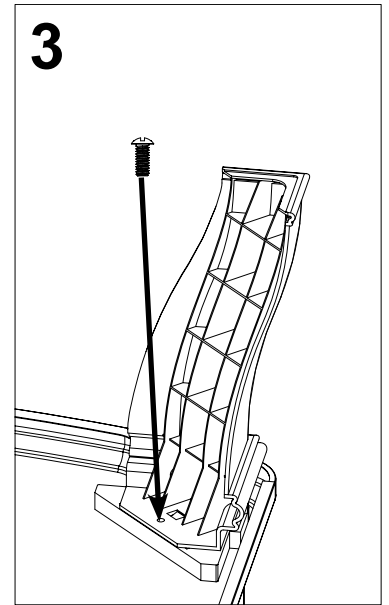

3  
Fasten the legs to the base using the included screws, 1 per leg

## CARE AND MAINTENANCE

- Clean the trim using a soft cloth, slightly dampened with citrus oil based product and buff with a clean soft cloth.
- DO NOT use brass polish or household cleaners as these products will damage the metal trim. Citrus oil based products can be obtained at supermarkets or hardware stores.
- Periodic cleaning/vacuuming of the filter is recommended.
- WARNING: Electrical outlet wiring must comply with local building codes and other applicable regulations to reduce the risk of fire, electrical shock and injury to persons.
- Warning: Disconnect power before attempting any maintenance or cleaning to reduce the risk of fire, electrical shock or personal injury.

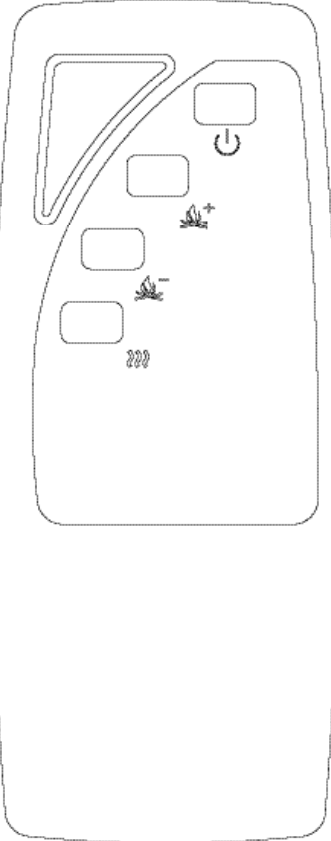
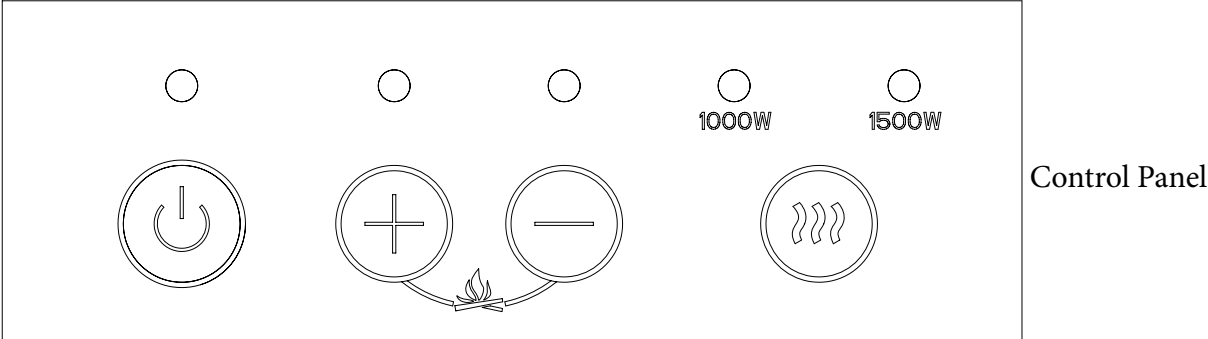
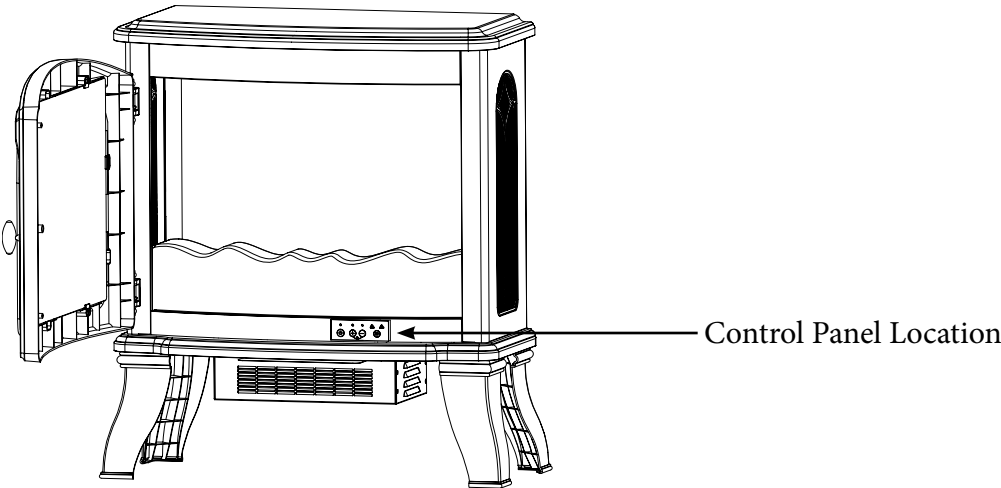

# OPERATION INSTRUCTIONS



NOTE: Please operate the remote transmitter at a slow measured pace. Press the remote control buttons with an even motion and gentle pressure. Repeatedly pressing buttons in rapid succession may cause the transmitter to malfunction.

# OPERATION INSTRUCTIONS

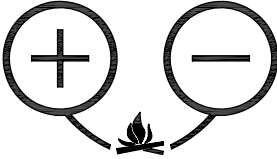
---

Function	Icon	Description
POWER		The Power button supplies power to all of the functions of the stove and will illuminate the flame effect. This switch must be lit for any of the functions to work.
FLAME		Use + or - to increase or decrease the flame brightness levels.
HEATER		Our stove consists of an infrared type heater. The HEATER button turns the heater ON and OFF. This button will be lit when the heater function is activated.

# BULB REPLACEMENT

## Tools Required for Assembly

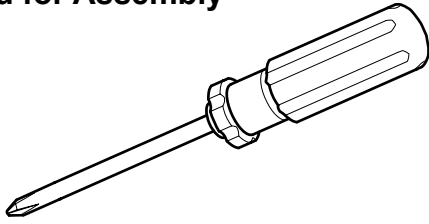

Phillips Head Screwdriver

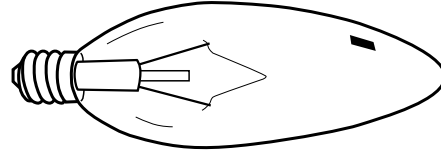

Clear, 40-watt, E12 socket base light bulb  
(candelabra base, B bulb).

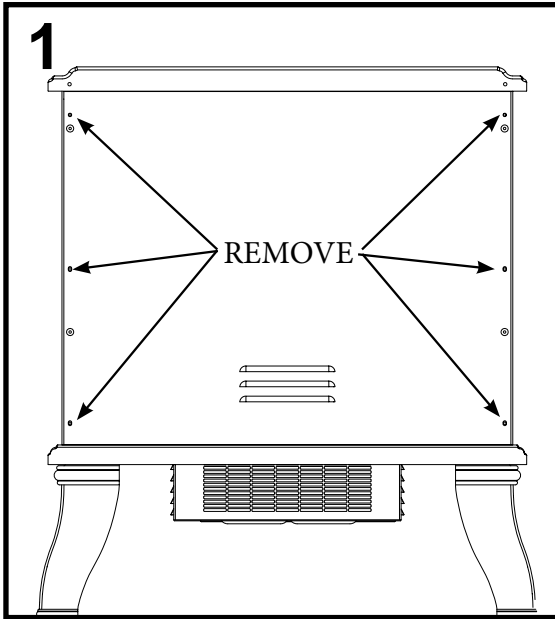

Unplug the stove. Remove the screws holding the stove back panel in place. Remove the back panel to access the light bulb.

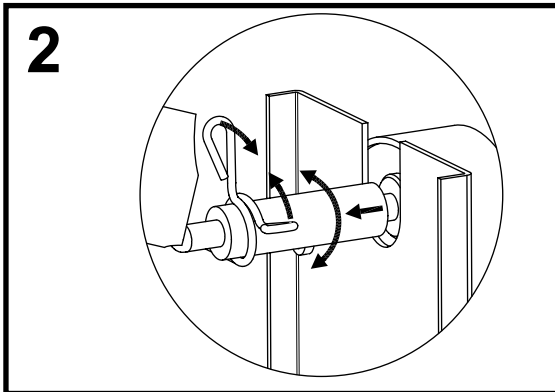

Pinch the spring clip to loosen the spindle, and gently turn and pull the rubber gromet out of the spinner motor shaft. Remove the spindle and set aside.

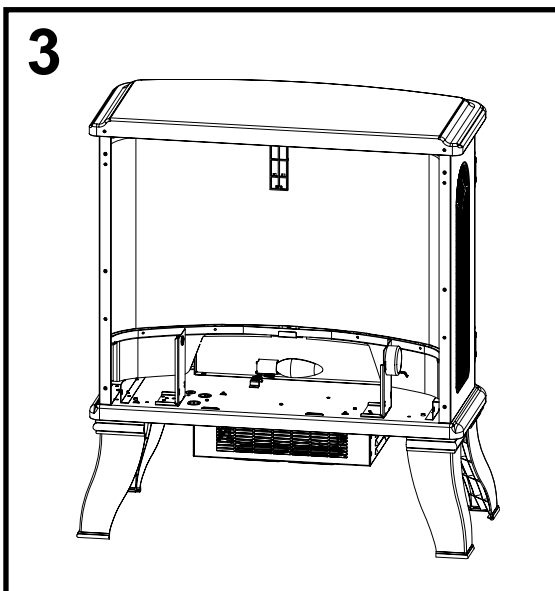

Remove light bulb and replace. Reverse steps 2 and 1; Replace spindle and re-install stove back panel into position; be careful to not overtighten the screws.

# TROUBLESHOOTING GUIDE

Problem	Root Cause	Corrective Action
1. No power, buttons do not light up.	1. Power cord was not plugged into the outlet.	1. Check that unit is plugged directly into a standard 120 volt outlet.
2. Stove does not turn on manually.	2a. No incoming power from the electrical wall socket or buttons. 2b. Improper operation. 2c. Defective button	2a. Check circuit breakers and move unit to another outlet. 2b. Manually press main power button from front of unit. 2c. Replace button
3. Flames are not moving	3a. Defective spinner motor 3b. Spinner detached from the motor	3a. Replace spinner motor 3b. Remove the back panel and check to see if “spinner” is correctly mounted to the motor.
4. Flames are not visible	4a. Burnt out light bulb	4a. Replace 40 watt candelabra bulb
5. Flames are not bright	5a. Normal operation 5b. Defective dimmer button	5a. Turn brightness dimmer knob until desired brightness is achieved. 5b. Replace dimmer button
6. Heater is not turning off	6a. Defective Thermostat Button	6. Replace Thermostat Button
7. Heater is not turning on	7a. Improper operation 7b. Defective heater blower motor	7a. Manually press main power button on front of unit. 7b. Replace heater blower motor.
8. Not producing enough heat	8a. power strip/surge protector/ extension cord being used 8b. Location of unit	8a. Plug unit directly into the wall. 8b. Make sure unit is located on an interior wall.
9. Unit blows cool or cold air	9. Defective heater blower motor	9. Replace heater blower motor
10. Noise with heater on	10a. Dirty heater blower motor 10b. Defective heater blower motor	10a. Gently vacuum heater blower vents. 10b. Replace heater blower motor
11. Noise with flames on and heater off	11a. Defective flame generator drive motor. 11b. Dented back panel 11c. Warped spinner shaft	11a. Replace flame generator drive motor. 11b. Refer to TSI customer service 11c. Refer to TSI customer service
12. Power cord gets warm	12. Normal operation	12. Check your heater cord and plug connections. Faulty wall outlet connections or loose plugs can cause the outlet or plug to overheat. Be sure the plug fits tight in the outlet. Heaters draw more current than small appliances, overheating of the outlet may occur even if it has not occurred with the use of other appliances. During use check frequently to determine if your plug outlet or faceplate is HOT! If so, discontinue use of the heater and have a qualified electrician check and/or replace the faulty outlet(s).
13. Is it safe to place unit on carpet?	13. Product Inquiry	13. It is safe to place unit on carpet but make sure any flammable items are at least 3 feet away from front and sides of the unit.
14. How many square feet will my unit warm up?	14. Product Inquiry	14. Provides supplemental heat up to 1000 square feet
15. Heater doesn't work, but Power and Heater buttons are in the “ON” position and thermostat is set on the highest level.	15. The thermal protector has tripped.	15. Turn all buttons to the “OFF” position and unplug the unit from the wall outlet for 5 minutes. After 5 minutes, plug the unit back into wall outlet and operate as normal.



# EXPLODED VIEW

Part	Part Name	Part Number
1	Control Panel	Y15-S168-P32
2	Legs	SL-3108-BLK
3	Heater/Blower Assembly	Y15-S168-01
4	Main PCBA	Y15-S168-P15
5	Flame Generator/Spinner	Y15-S168-P11
6	Flame Generator Drive Motor	P10-Q
7	Emberbed	Y15-S168-P02
8	Remote control	P130

Note, the scale and size of your parts may be different depending on your exact model

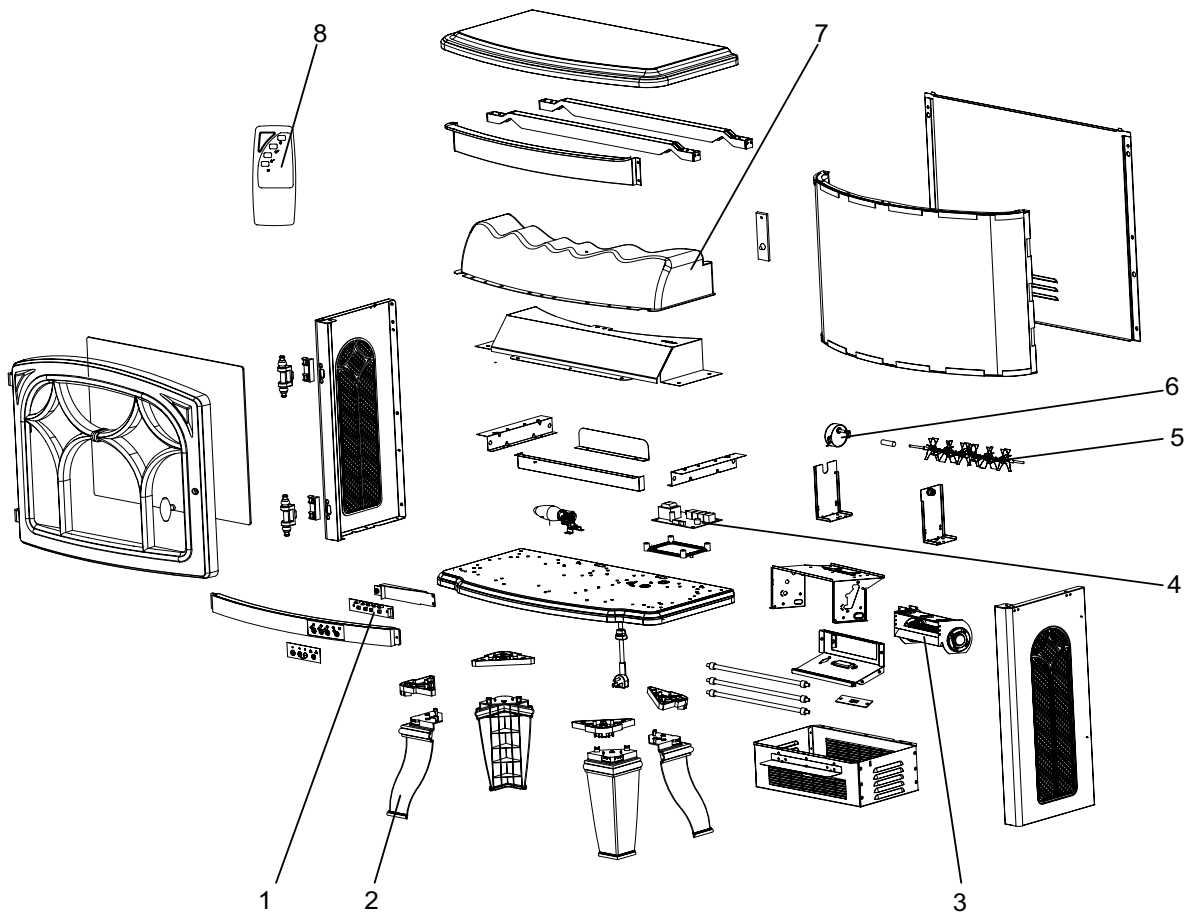

# FCC/IC INFORMATION

**Warning:** Changes or modifications to this unit not expressly approved by the party responsible for compliance could void user's authority to operate the equipment.

**NOTE:** This equipment has been tested and found to comply with the limits for Class B digital device, pursuant to part 15 of the FCC Rules. These limits are designed to provide reasonable protection against harmful interference in a residential installation. This equipment generates, uses, and can radiate radio frequency energy and, if not installed and used in accordance with the instructions, may cause harmful interference to radio communications.

However, there is no guarantee that interference will not occur in a particular installation. If this equipment does cause harmful interference to radio or television reception, which can be determined by turning the equipment off and on, the user is encouraged to try to correct the interference by one or more of the following measures.

- Reorient or relocate the receiving antenna.
- Increase the separation between the equipment and the receiver.
- Connect the equipment into an outlet on a circuit different from that to which the receiver is connected.
- Consult the dealer or an experienced radio/TV technician for help.

This device complies with Part 15 of the FCC Rules. Operation is subject to the following two conditions:

- (1) This device may not cause harmful interference, and
- (2) this device must accept any interference received, including interference that may cause undesired operation. Modifications not approved by the party responsible for compliance could void user's authority to operate the equipment.

This Class B digital apparatus complies with Canadian ICES-003.

# BATTERY REPLACEMENT

**NOTE:** Do not mix old and new batteries.

Do not mix alkaline, standard (carbon zinc), or rechargeable (nicad, nimh, etc.) batteries.

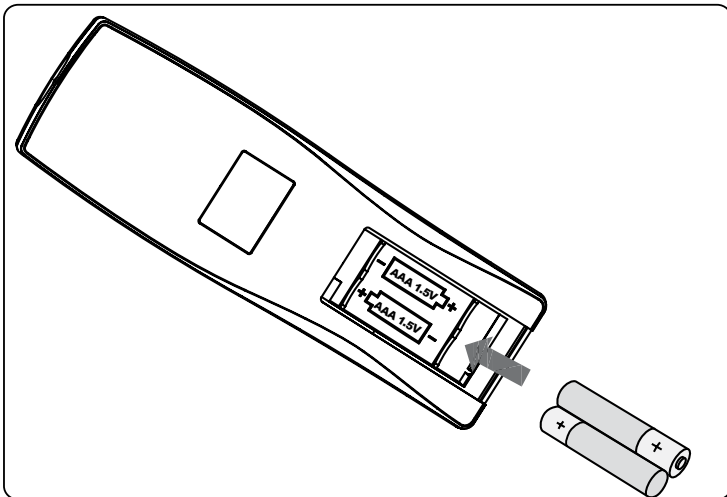

## Note:

### Battery disposal

Please always dispose of batteries at a suitable recycling point.

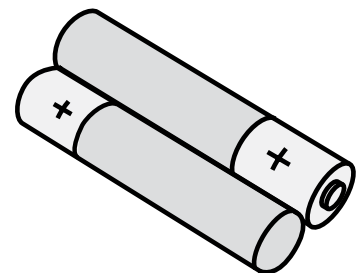

## CAUTION:

- Always purchase the correct size and grade of battery most suitable for the intended use.
- Replace all batteries of a set at the same time.
- Clean the battery contacts and also those of the device prior to battery installation.
- Ensure the batteries are installed correctly with regard to polarity (+ and -).
- Remove batteries from equipment which is not to be used for an extended period of time.
- Remove used batteries promptly.

Caution: Do not ingest batteries.

Non-rechargeable batteries are not to be recharged.

Batteries are to be inserted with the correct polarity.

Exhausted batteries are to be removed from the product.

# 1-YEAR LIMITED WARRANTY

---

The manufacturer warrants that your new Electric Stove is free from manufacturing and material defects for a period of one year from date of purchase, subject to the following conditions and limitations.

1. Install and operate this appliance in accordance with the installation and operating instructions furnished with the product at all times. Any unauthorized repair, alteration, willful abuse, accident, or misuse of the product shall nullify this warranty.
2. This warranty is non-transferable, and is made to the original owner, provided that the purchase was made through an authorized supplier of the product.
3. The warranty is limited to the repair or replacement of part(s) found to be defective in material or workmanship, provided that such part(s) have been subjected to normal conditions of use and service, after said defect is confirmed by the manufacturer's inspection.
4. The manufacturer may, at its discretion, fully discharge all obligations with respect to this warranty by refunding the wholesale price of the defective part(s).
5. Any installation, labor, construction, transportation, or other related costs/expenses arising from defective part(s), repair, replacement, or otherwise of same, will not be covered by this warranty, nor shall the manufacturer assume responsibility for same.
6. The owner/user assumes all other risks, if any, including the risk of any direct, indirect or consequential loss or damage arising out of the use, or inability to use the product, except as provided by law.
7. All other warranties – expressed or implied –with respect to the product, its components and accessories, or any obligations/liabilities on the part of the manufacturer are hereby expressly excluded.
8. The manufacturer neither assumes, nor authorizes any third party to assume on its behalf, any other liabilities with respect to the sale of the product.
9. The warranties as outlined within this document do not apply to non accessories used in conjunction with the installation of this product.
10. This warranty gives you specific legal rights, and you may also have other rights which vary from state to state.

This warranty is void if:

- a. The fireplace is subjected to prolonged periods of dampness or condensation.
- b. Any unauthorized alteration, willful abuse, accident, or misuse of the product.
- c. You do not have the original receipt of purchase.

## CUSTOMER SERVICE

---

[www.tsicustomerservice.com](http://www.tsicustomerservice.com)

For Customer Service Call 1-888-674-7517

Questions? Our message centers are available 7 days a week 24 hours a day at our toll-free help line. Our Consumer Service department is available Monday – Friday 8:30 am – 5:30 pm EST. We can help you with assembly and if necessary, replace damaged/missing parts.

**IMPORTANT:**

Before contacting Customer Service please have this information available:

- Serial Number
- Model Number
- Sales Receipt or Proof of Purchase