

ASSEMBLY AND CARE INSTRUCTIONS
IMPORTANT: RETAIN FOR FUTURE REFERENCE. READ CAREFULLY

☎ **1-800-711-1585** Monday thru Friday 9:00 AM to 5:00 PM (PST) (English, French and Spanish available)

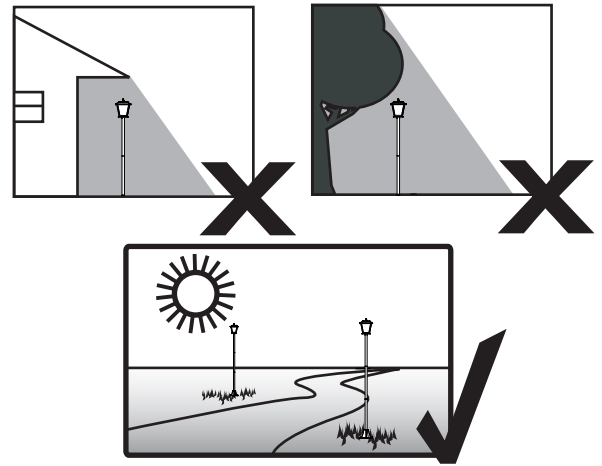
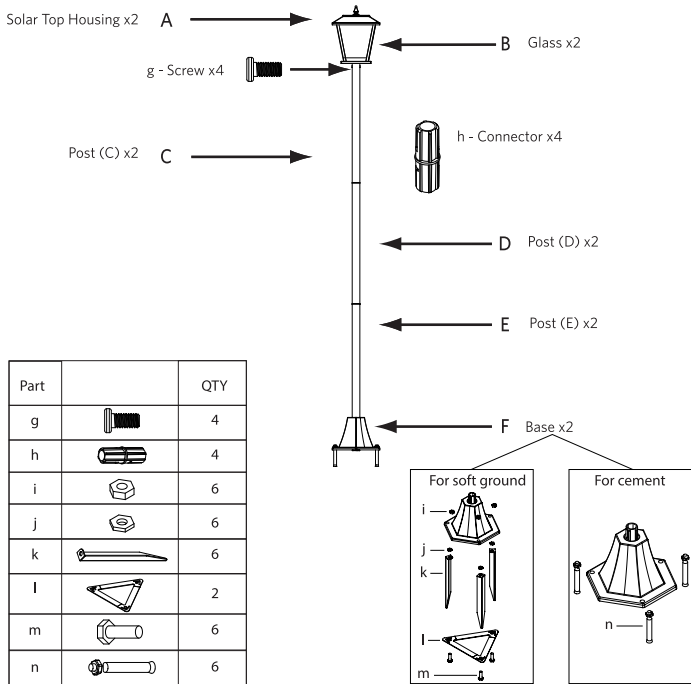

How solar lights work

Solar lights have a solar cell that converts sunlight into electricity. This electricity is used to recharge the built-in battery each day. A built-in sensor automatically turns on the light at night. The more sunlight received during the day, the longer the light will operate that night. Since solar lights are powered entirely by sunlight they receive each day, operating times will vary by specific location, daily weather conditions, and season.

Assembly

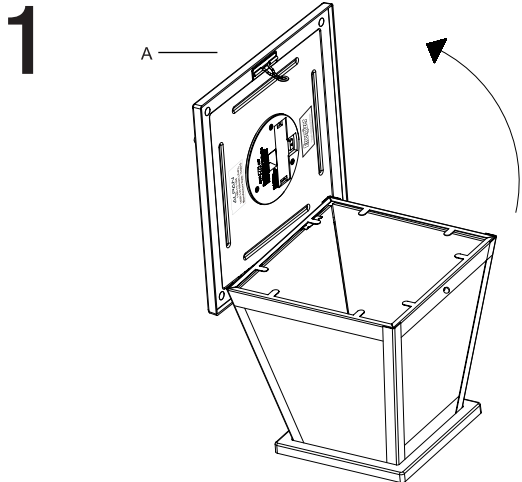

- # 2
- For first time use, remove pull tab from the battery compartment, located on the Solar top Housing (A).
 - Turn switch to "AUTO."

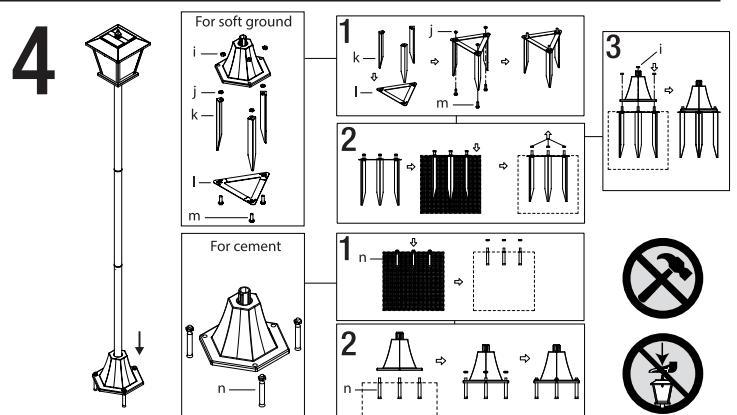
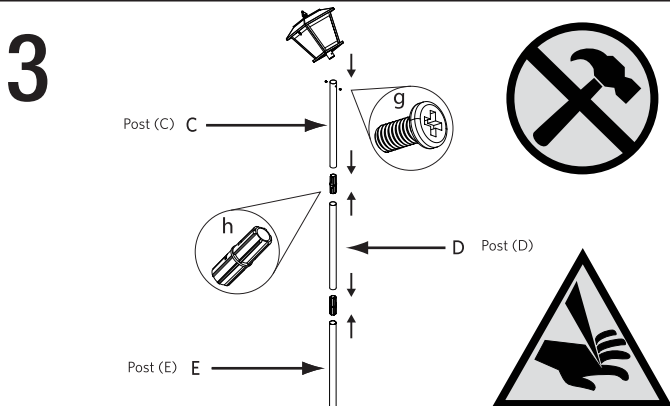
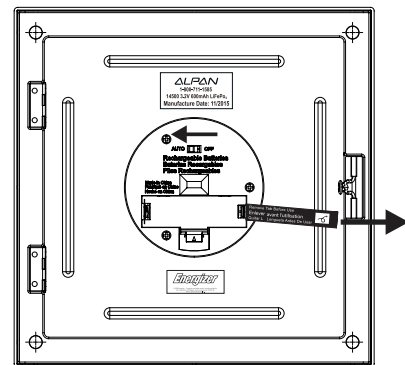

Care & Cleaning

- Clean the solar panel with a damp cloth. Do not use any chemicals or abrasives.
- Keep the solar panel free of snow and debris to allow the battery to charge properly.

CAUTIONS: BATTERY INSTRUCTIONS

- Always purchase the correct size and grade of battery most suitable for the intended use.
- Always replace the whole set of batteries at one time, taking care not to mix old and new ones, or batteries of different types.
- Clean the battery contacts and also those of the device prior to battery installation.
- Ensure the batteries are installed correctly with regard to polarity (+ and -).
- Remove batteries from equipment which is not to be used for an extended period of time.
- Remove used batteries promptly.

For recycling and disposal of batteries to protect the environment, please check the internet or your local phone directory for local recycling centers and / or follow local government regulations.

⚠ CAUTION: Do not dispose of the battery in fire.

! IMPORTANT: Dispose of the battery in accordance with local, state, and federal regulations.

Maintenance

1 Replacing the battery

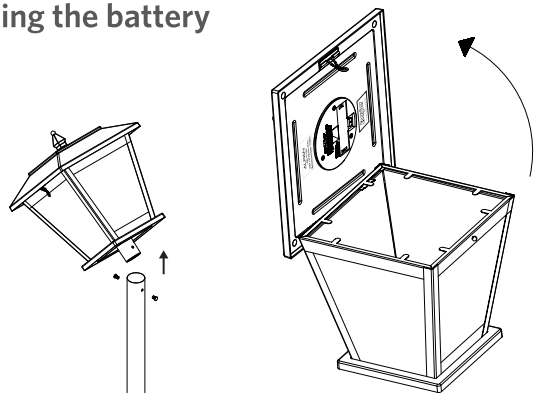

2

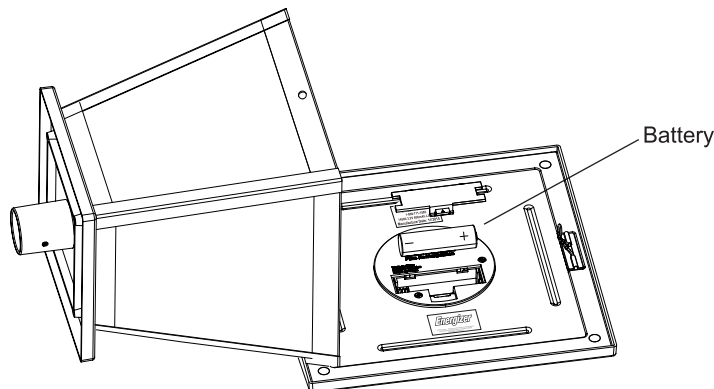

Important : Use only Lithium Phosphate 14500 (3.2V 600mAh) rechargeable batteries.

Troubleshooting

Problem	Solution
Light stops working after period of working properly.	<ul style="list-style-type: none"> □ The battery is not adequately charged. Place the unit in direct sunlight for three sunny days. □ The lights are located in a location that does not provide enough sunlight. If a tree, house, or other object is shading the solar light, move the light to a sunnier location. Also note that lighting time will always be shorter on overcast days. □ The light level is too high for the solar lights to turn on. The solar lights are designed to turn on when it is dark outside. Make sure the solar top housing is not under any direct light source when testing. □ The battery may be weak or can no longer produce a charge. Replace the battery.
The lights only operate for a short duration in the evening.	<ul style="list-style-type: none"> □ The lights are located in a location that does not provide enough sunlight. If a tree, house, or other object is shading the solar light, move the light to a sunnier location. Also note that lighting time will always be shorter on overcast days. □ The battery may be weak or can no longer produce a charge. Replace the battery.

Manufacturer's One Year Limited Warranty

Manufacturer warrants this product to be free for one (1) year against any defects that are due to faulty materials or workmanship. Manufacturer shall promptly correct such defects by repair or replacement, at its option. This warranty covers only product defects and shall expire one year after the date of purchase by the original purchaser. Proof of Purchase (Sales Receipt) is required.

This warranty does not apply to (1) bulbs and batteries or (2) defects caused by and resulting from misuse, neglect, accident or improper operation, maintenance, storage, transportation handling of the product. The warranty does not cover any transportation costs for return of the product or for reshipment of any repaired or replaced product, or cost associated with installation, removal or reinstallation of the product. This warranty extends to the original purchaser only and is not transferable or assignable to subsequent purchasers. This warranty does not cover surface scratches or weathering as this is considered normal wear.

Manufacturer shall have no responsibility for damage to persons or property or other loss or injury resulting from a defect in the product or from improper use or installation. UNDER NO CIRCUMSTANCES SHALL MANUFACTURER BE LIABLE SPECIAL OR CONSEQUENTIAL DAMAGES. ANY WARRANTIES IMPLIED BY LAW, INCLUDING THOSE OF MERCHANTABILITY AND FITNESS FOR A PARTICULAR PURPOSE, ARE LIMITED IN DURATION TO ONE YEAR AFTER THE DATE OF THE ORIGINAL PURCHASE. In no event shall Manufacturer's liability under this warranty exceed the cost of repair or replacing such defective product, and Manufacturer's maximum liability under any warranty is in lieu of all other warranties expressed or implied.

Some states do not allow the exclusion or limitation of special or consequential damages or allow limitations on how long an implied warranty lasts, so the above limitation may not apply to you. This warranty gives you specific legal rights, and you may have rights that vary from state to state. If you feel you have a claim under this warranty, contact consumer service for advice on handling the claim. Written notice of any defects must be given to Manufacturer upon discovery.